

REPORT ITU-R F.2106

Fixed service applications using free-space optical links

(Question ITU-R 237/9)

(2007)

Scope

This Report provides a response to Question ITU-R 237/9 concerning free-space optical (FSO) links (FSOL) for fixed service (FS) applications.

The following sections present equipment characteristics, possible FS applications as well as technical and operational aspects of the free-space optic transmission (see Notes 1 and 2).

NOTE 1 – The free-space transmission discussed in this Report focuses on systems for outdoor use.

NOTE 2 – Free-space optic connection between a hub station and mobile/nomadic terminals serving as wireless local area network is outside the scope of this Report; however, a fixed link between hub stations is covered by this Report.

Abbreviations

AAC:	Automatic attenuation control
APD:	Avalanche photo diode
FSO:	Free-space optics
FSOL:	Free-space optical link
LD:	Laser diode.

References**ITU-R Recommendations**

Recommendation ITU-R F.1668 – Error performance objectives for real digital fixed wireless links used in 27 500 km hypothetical reference paths and connections

Recommendation ITU-R F.1703 – Availability objectives for real digital fixed wireless links used in 27 500 km hypothetical reference paths and connections

Recommendation ITU-R P.1814 – Prediction methods required for the design of terrestrial free-space optical links

Recommendation ITU-R P.1817 – Propagation data required for the design of terrestrial free-space optical links.

ITU-T Recommendations

ITU-T Recommendation G.640 – Co-location longitudinally compatible interfaces for free-space optical systems

ITU-T Recommendation G.692 – Optical interfaces for multichannel systems with optical amplifiers.

1 Introduction

Recently FSO links (FSOLs) are becoming attractive transport media for short-range fixed applications. FSOL has the following advantages:

- broadband transmission is available;
- transmit/receive equipment is compact;
- there is almost no need for coordination to avoid interference between FSOLs.

Therefore, in order to expand its current and future applications, technical and operational aspects of FSOL need to be addressed through theoretical analyses as well as experimental approaches as described in this Report.

2 Description on system configuration and basic parameters

2.1 Explanation of parameters

2.1.1 Transmitter side

2.1.1.1 Emission area, E_a

Emission area, E_a , is the surface of the transmitting window expressed in square metre (m^2).

The emission area is a parameter used for the determination of a laser safety class.

2.1.1.2 Emission power, E_p

Emission power, E_p , is the power transmitted through the Emission area, E_a , expressed either in dBm or in mW. It is one of the other parameter used for the determination of the laser safety class and used to calculate the link margin. The power measurement should be performed outside the FSO and as close as possible to the FSO emission windows. If possible, the measurement should be performed transmitting “0” and “1” with equal probabilities of occurrence. The power is the averaged value of the high level value (“1” bit) and of the low level value (“0” bit).

For safety reason, it is necessary to determine the accuracy of the power measurement, e.g. $E_p = 10 \text{ dBm} \pm 1 \text{ dB}$.

Also for safety reasons, if the terminal has an automatic divergence adjustment, the E_p is defined for the minimum divergence value, and, for the terminal with Automatic Transmit Power Control (ATPC), the maximum E_p value is the maximum value of the emission power.

For terminals having a multibeam system, the E_p on each E_a and the total (sum of the beams – mW) should be indicated. The total is the sum of all the E_p for each emission terminal when all beams converge and this parameter is used for safety reason. The distance between two E_a with the beam divergence should also be indicated.

For terminals having a holographic optical diffuser to achieve a super-extended source, in order to provide a high level of diffusion transmission efficiency with a controlled diffusion area, and increase the transmission efficiency with a class 1 (following the IEC 60825-1 standard [3]) configuration; the E_p based on E_a should be indicated.

2.1.1.3 Beam divergence, B_d or θ

The beam divergence, B_d , is the maximum value of the angles between the beam central axis corresponding to the maximum power density and the direction corresponding to a power density -3 dB lower.

This value is important for the determination of the laser safety class and to calculate the link margin. The value can be expressed as half angle or full angle, but should be noticed; and the unit is usually expressed in milliradian (mrad). In case of adjustment divergence, the minimum and the maximum values should be indicated.

2.1.1.4 Wavelength, W_a or λ

The wavelength, W_a or λ , is the central wavelength and its full width at half maximum (FWHM). The central wavelength value is also important for laser safety class calculation. The unit should be in nanometres (e.g.: $\lambda = 849 \pm 2$ nm).

If there is a wavelength division multiplexing (WDM) transmission, it could be easier to indicate the spectral range.

2.1.1.5 Laser safety class

The FSO terminal safety class follows the IEC 60825 normative reference and has to be controlled by a certified laboratory. The 1 or 1M safety class for FSO terminal should be preferred.

2.1.2 Receiver side

2.1.2.1 Receiver area, R_a

Receiver area, R_a , is the complete receiver area or surface through the receiver window and the unit can be measured in metres squared (m^2).

2.1.2.2 Sensitivity, S_e

Sensitivity, S_e , is the minimum optical level with a considered data quality transmission (for instance, BER should be better than 10^{-6} ; i.e. $BER \leq 10^{-6}$).

The unit should be dBm and the measurement should be achieved close to the FSO receiver window.

If the terminal has multireceiver windows, S_e on each R_a and the total sensitivity should be indicated.

If the terminal has a reception system formed by micro-sphere doped, A, by doping element, A', according to the resonance wavelength of the incidental beam, B, interfaced with a laser transmitter, C, with definite wavelength and adjustable power offering an energy contribution in link at the frequency of resonance of the doping elements contained in the micro-spheres; the terminal, D, sensitivity, S_e , will be the sensitivity of such a system with the same considered data quality transmission (Fig. 1).

FIGURE 1
Terminal with micro-sphere

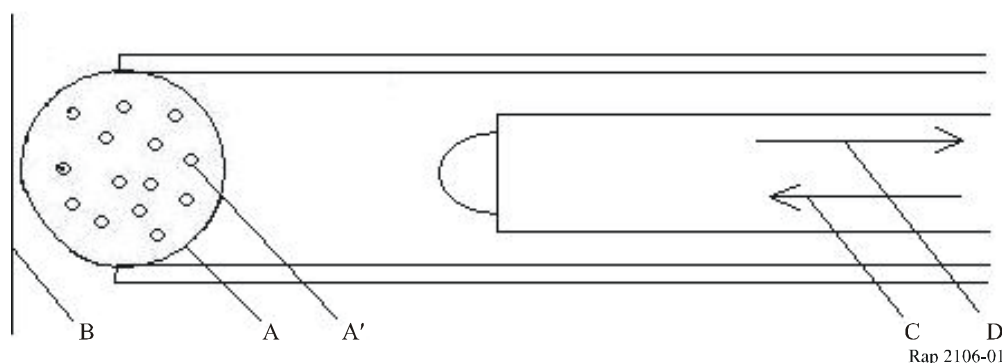

2.1.2.3 Saturation sensitivity, S_s

Saturation sensitivity, S_s , is the maximum optical level with a considered data quality transmission (for instance, BER should be better than 10^{-6} ; i.e. $BER \leq 10^{-6}$); with and without automatic attenuation control (AAC).

The unit should be in dBm and the measurement should be achieved closer to the FSO receiver windows.

If the terminal has multireceiver windows, S_e on each R_a and the total sensitivity should be indicated.

The difference between the saturation sensitivity (with AAC if any) and the sensitivity gives the dynamic range.

2.1.2.4 Field of view, F_v

The Field of view, F_v , is the angle between the central axis and the -3 dB value angle detection. The value can be expressed as half angle or full angle, but has to be mentioned; and the unit can be expressed in milliradian (mrad).

2.1.2.5 System loss, S_l

This element shall be used as an indication and it is not used for laser safety class and link margin calculation, due to the emission and receiver measurement points. The unit should be in dB.

2.2 System configuration

Basic configuration of a FSOL for the FS applications is illustrated in Fig 2.

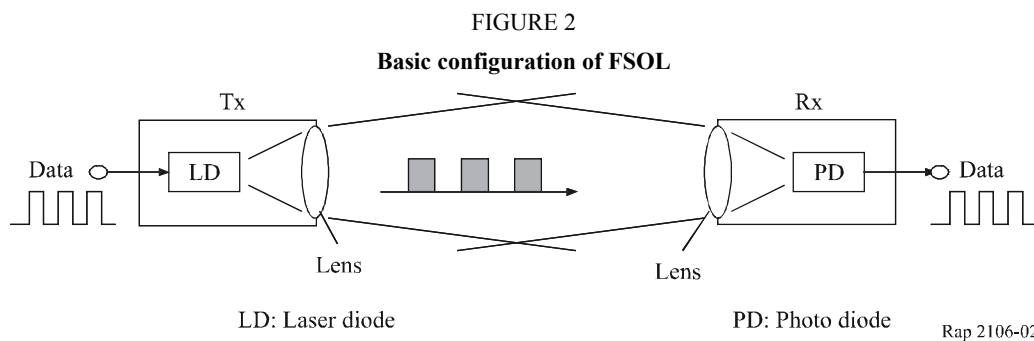

In many FSOLs, the function of electrical/optical (E/O) or optical/electrical (O/E) conversion is implemented in the LD in the Tx or in the PD in the Rx, respectively. Recently, some systems adopted the WDM technique in which more than one optical carrier can be accommodated in a couple of transmitters and receivers to increase the link capacity [1] [2]. WDM systems, however, may need further development in particular in the branching filter technology at the receiving side from a viewpoint of economical use.

The equipment uses the modulation of a laser beam to exchange binary data in both directions through a transmitter/receiver couple (Laser diode/APD or PIN diode) at each end. The equipment is used for point-to-point, bilateral links and in line of sight (LoS).

Each equipment consists of several modules:

- For the transmission:
 - a) the tributary interface: electric or optics to send and receive digital data;
 - b) the E/O conversion module (in the event of optical interface);
 - c) the filtering and the amplification of the electric digital signal;
 - d) the optical transmission module containing the laser.
- For the reception:
 - a) the optical receiver module containing the diode;
 - b) the filtering and the amplification of the electric digital signal;
 - c) the O/E conversion module (in the event of optical interface);
 - d) the tributary interface: electric or optics to send and receive the digital data.

A management software is sometimes provided with the equipment and allows to configure the link and to obtain qualitative and quantitative information from the different modules.

Additional functionalities are implemented depending on to the manufacturers, such as:

- a tracking system, ATPC, AAC;
- a radio assistance link, with a limited rate, in the event of a laser link interruption.

An example of FSO equipment structure is presented in Fig. 3.

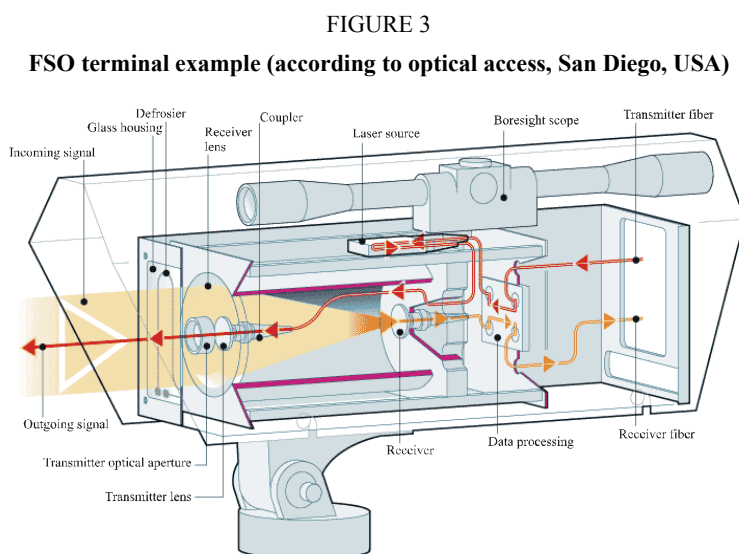

Rap 2106-03

2.3 Basic system parameters

The main parameters to take into account in the definition of optical links are the following:

Range: This varies according to the equipment from a few tens of metres to several kilometres. Some manufacturers give a maximum range, others specify the typical range for various weather conditions, and others finally propose a “recommended” range, integrating a margin compared to the maximum value. These values must be taken as orders of magnitude, and not as absolute values.

Safety: An important factor to take into account is the laser category of the equipment, because its conditions are more or less easy methods for the installation and the maintenance of an FSO link. The parameters to be taken into account when defining laser category are the signal wavelength, the encountered powers and the beam shape. It is advised to choose a 1 or 1M class terminal based on IEC 60825-1 normative reference.

Data rate and type of recommended application: Many systems are transparent to data rate and to protocol; for a data rate range, this is often relatively important. The applications then depend on the maximum capacity, which the system can transmit and are located invariably in telecommunications or in the data processing world. A transparent system up to 200 Mbit/s will be able to transmit for instance STM-1, ATM, FDDI or Fast Ethernet signals. Other terminals are specified for a data rate, an interface and thus a given use, for example the E1 (2.048 Mbit/s), or Ethernet data (10 Mbit/s).

Frequencies/wavelengths used for FSOL: There are two major frequency/wavelength ranges that are widely utilized for FSOL applications, i.e. 230-200 THz/1 300-1 500 nm range and 375-385 THz/780-800 nm range. These ranges have advantages compared to other ranges, that the atmospheric absorption over the free-space is fairly small. Also, in optical fibre systems, the transmission characteristics present such good performance in these wavelength ranges that the semiconductor light devices are economically available. A precise control technology for the wavelength has been developed in particular around the 1 500 nm range, where WDM technique is currently considered. In this relation, studies on the wavelength arrangements for optical fibre transmission have been conducted by ITU-T Study Group 15. From a viewpoint of atmospheric transmittance, a wavelength range 2 000-2 200 nm is also convenient, since effects of the aerosol scattering and the molecule absorption become minimum in this range, in particular around 2 200 nm [10] [11]. This range has another advantage that it is less sensitive to optical beam bending caused by atmosphere temperature variation (see § 7.1). On the other hand, economical light devices for both signal generation and detection are not yet feasible in the 2 000-2 200 nm range. ITU-R Study Group 3 (Working Parties 3J and 3M) has studied free-space optical propagation characteristics for wide range of optical frequencies including both satellite and terrestrial links (see § 3).

Transmit power of the laser diode: Transmit power of the laser diode (LD) used for FSOL is currently in the order of 10 mW. Therefore, the link design discussed in the later section is based on this value. However, technology development will bring about optical devices with much higher capability and this may expand scope and applications of FSOL in the near future.

The following secondary parameters are also to be taken into account for the choice of a system:

- the wavelength to which the optical link operates: this parameter influences the safety class of the terminal;
- the type and number of optical transmitters and/or receivers influence the link margin;
- a simple process of implementation and maintenance actions;
- simple, convivial supervision software, allowing a management for the two (or several) terminals (or several links) from only one site (remote control);
- and, the cost of the system.

3 Free-space propagation characteristics relating to the link design

This section provides free-space propagation characteristics for FSOL based on the study results in the ITU-R P-Series Recommendations. For more detailed background of the material within this section, the relevant P-Series Recommendations (Recommendations ITU-R P.1814 and ITU-R P.1817 could be referred to.

3.1 Clear-sky propagation

In optical wave propagation, the atmospheric attenuation is experienced in addition to what is called the free-space loss even during clear weather. This attenuation, L_{atm} , is caused by Rayleigh scattering and/or molecule absorption, the effect of which greatly depends on the wavelength.

Also, the receiving power fluctuates due to temperature gradient turbulence within the atmosphere, which produces beam-bending, spot-dancing or scintillation in the optical wave propagation path.

Usually the effect of L_{atm} is not so large in the wavelength ranges mentioned in § 2.3 (frequency/wavelength for FSOL) for links shorter than about 1 km. The link outage caused by such phenomena can be easily reduced by adjusting the optical beam divergence at the transmitting side so that the diameter of the beam spot at the receiver side would become a certain size, e.g. up to several metres.

Another way to improve the link availability against the affect of the propagation is to adopt a signal retransmission scheme and/or forward-error correction in the electrical layer.

3.2 Effect of fog

3.2.1 Estimation of fog attenuation using atmosphere visibility

Attenuation due to fog is caused by Mie scattering [4], which is dependent on the number of particles (fog density). It is generally difficult to directly measure fog density or to obtain its statistical data. The effect of the attenuation due to fog, Att_{fog} (dB/km), can be related to atmosphere visibility, V (km), defined by the maximum distance that we can recognize a black object against the sky [5] [6]. More specifically, the visibility is defined for meteorology purposes. It is characterized by the transparency of the atmosphere estimated by a human observer. It is measured according to the meteorological Optical Range and by using a transmissometer or a diffusiometer.

In current cases, measurement of visibility, V , is given by the distance at which the transmitted optical power drops to ϵ times its original value. In the literature, the two following values of ϵ are found $\epsilon = 0.02$ or $\epsilon = 0.05$.

Then the relation between Att_{fog} and V can be expressed by the following equation, which can be applied independently of the type of fog and of the optical wavelength within the range of V smaller than 3 km.

$$Att_{fog} = 10\log_{10}(\epsilon)/V \quad (1)$$

Thus, the attenuation of optical waves due to fog can be estimated using visibility statistics. The above prediction method based on equation (1) has been demonstrated and taken into consideration in the link design [5] [7]. Fig. 4 illustrates the relation between Att_{fog} and V for the measured data [7].

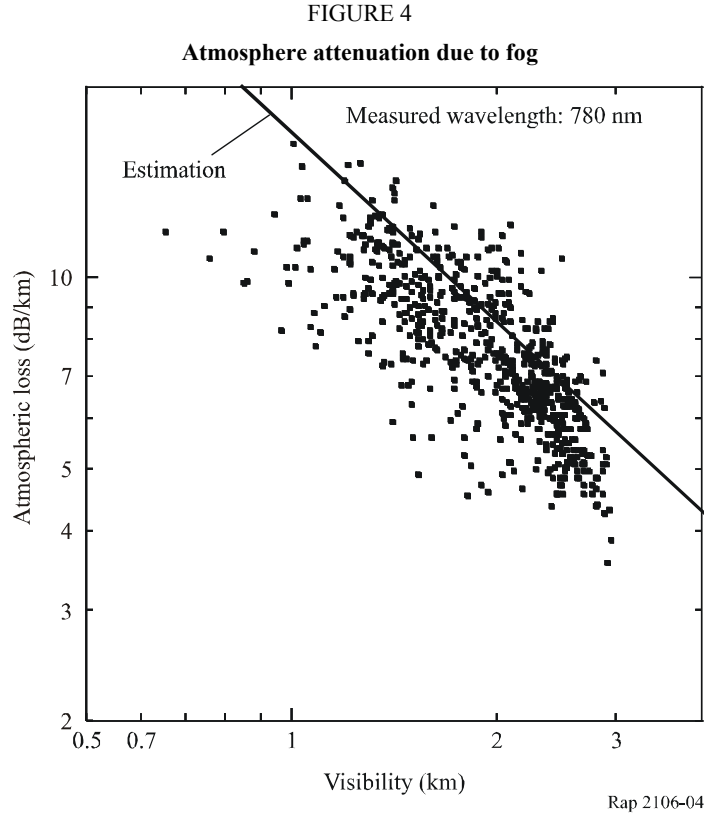

3.2.2 Detailed analysis on aerosol attenuation (fog)

In this sub-section, more detailed analysis is presented for cases when the type of fog is known.

Atmospheric attenuation results from an additive effect of absorption and dispersion of the infrared light by aerosols and gas molecules present in the atmosphere. Transmittance in function of the distance is given by Beer Lambert relation:

$$\tau(\lambda, d) = \frac{P(\lambda, d)}{P(\lambda, 0)} = \exp[-\sigma(\lambda)d] \quad (2)$$

where:

- $\tau(\lambda, d)$: transmittance at the distance d of the transmitter;
- $P(\lambda, d)$: transmitted power at a distance d ;
- $P(\lambda, 0)$: transmitted power;
- $\sigma(\lambda)$: specific attenuation or extinction coefficient per unit of length.

Attenuation due to fog over a d (km) link is connected to transmittance by the following expression:

$$Att_{fog,d} = 10 \log_{10}(1/\tau(\lambda, d)) \quad \text{dB} \quad (3)$$

The extinction coefficient $\sigma(\lambda)$ is the sum of 4 terms:

$$\sigma(\lambda) = \alpha_m(\lambda) + \alpha_a(\lambda) + \beta_m(\lambda) + \beta_a(\lambda) \quad (4)$$

where:

- α_m : molecular absorption coefficient (N₂, O₂, H₂, HO, CO₂, O₃, ...)
- α_a : absorption coefficient by the aerosols (small solid or liquid particles present in the atmosphere (ice, dust, smoked, ...))
- β_m : Rayleigh scattering coefficient resulting from the interaction of the wave with particles of a smaller size than the wavelength
- β_a : Mie scattering coefficient. It appears when particles are of the same order of magnitude as the transmitted wavelength.

Absorption dominates in the infrared while scattering dominates in the visible and ultraviolet range. Basically, the atmospheric attenuation (function of wavelength) is inversely proportional to visibility, a parameter characterizing the atmosphere opacity in presence of fog. The low values of molecular and aerosol absorption coefficients as well as Rayleigh scattering coefficient, extinction coefficient can be written by the following Al Naboulsi & Al relations:

Advection fog generated when the warm, moist air flows over a colder surface:

$$\sigma(\lambda)_{fog,adv} = \frac{0.11478\lambda + 3.8367}{V} \quad (5)$$

Radiation fog generated by radiative cooling of an air mass during the night radiation when meteorological conditions are favourable:

where:

$$\sigma(\lambda)_{fog,rad} = \frac{0.18126\lambda^2 + 0.13709\lambda + 3.8367}{V} \quad (6)$$

where:

λ : FSO wavelength (μm)

V : visibility (km).

NOTE 1 – These relations have been calculated for a wavelength located between 690 and 1 550 nm and visibility between 50 and 1 000 m, fog attenuation for a laser radiation and for two types of fog available in FASCOD, advection and radiation. These two relations are only valid for a distance between 50 m and 1 000 m and it is up to the user to choose one of the relations, which corresponds to the type of fog.

3.3 Effect of rain

In the case of rain, attenuation is caused by geometric scattering due to raindrops. Independent of the wavelength, this attenuation $Attrain$ (dB/km) is theoretically related to the raindrop size distribution, fI , by the following:

$$Attrain = 27.29 \times 10^5 \cdot \int_0^{\infty} r^2 \cdot fI \, dr \quad (7)$$

where:

r : diameter of rain drops (m)

For a certain location and a link distance, fI can be given by the statistical data of rainfall rate (in many cases one hour rate R (mm/h)) as follows [8]:

$$fI = B \exp(C R^k) \quad (8)$$

Examples of the parameters used in equation (8) are as follows according to the statistics collected in Japan:

Example (based on Marshall and Palmer model); $B = 0.16$, $C = -82$, and $k = -0.21$.

Then, the effect of Att_{rain} can be generally derived as a function of the precipitation intensity R (mm/h) using equations (7) and (8).

$$Att_{rain} = \alpha * R^\beta \quad (9)$$

Rain intensity is the fundamental parameter used to locally describe the rain. The parameters α and β will be given according to the location (see Table 1). The parameters obtained in France are consistent with those in Recommendation ITU-R P.1814.

TABLE 1

Examples of the parameters used for rain attenuation estimation

Location	α	β
Japan	1.58	0.63
France	1.076	0.67

The above prediction method, which is basically similar to that for the millimetric range electrical wave [9], has been proven to provide good estimation in optical wave propagation [5] [7] [15].

The measurement of rain intensity is carried out either directly by means of pluviometers or weather radars. Knowing the link margin deduced from the optical power link budget, the interruption probability of the link due to rain can be deduced, by dichotomy. A calculation example using the parameters measured in France is given as follows:

Example:

$$R = 18 \text{ mm/h}$$

$$Att_{rain} = 1.076 \times 18^{0.67} = 7.46 \text{ dB/km}$$

$$Att_{rain} = 7 \text{ dB/km.}$$

Figures 5a) and 5b) illustrate the relations between Att_{rain} using parameters in Table 1 and R for the data measured in Japan [7]. It is observed that, in the heavy rainfall region, estimation based on Recommendation ITU-R P.1814 also presents good approximation to the measured data obtained in Japan.

FIGURE 5

Atmosphere attenuation due to rainfall

a) Example 1

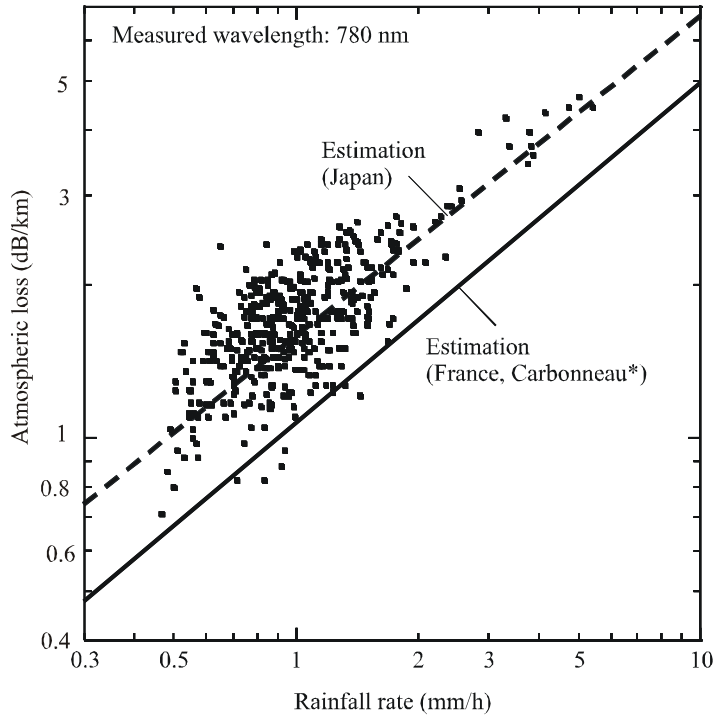

* This estimation is consistent with Recommendation ITU-R P.1814

b) Example 2

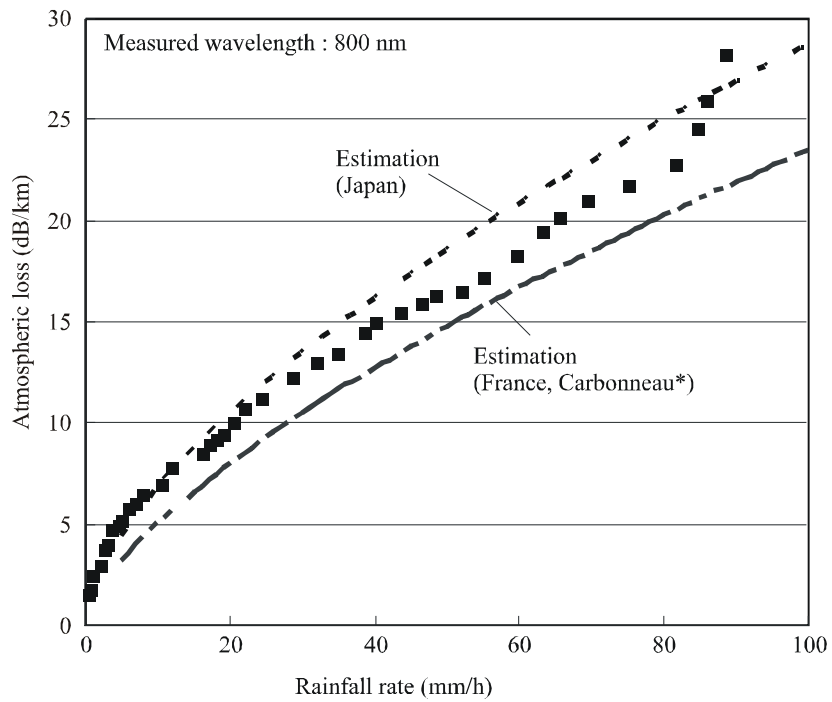

* This estimation is consistent with Recommendation ITU-R P.1814

3.4 Snow attenuation

Attenuation due to snow is a function of the wavelength, λ_{nm} , and precipitation intensity S (mm/h) according to the following relations:

- Wet snow (altitude <500 m):

$$Att_{snow} = (0.0001023 * \lambda_{nm} + 3.7855466) * S^{0.72} \quad \text{dB/km} \quad (10)$$

- Dry snow (altitude > or = 500 m)

$$Att_{snow} = (0.0000542 * \lambda_{nm} + 5.4958776) * S^{1.38} \quad \text{dB/km} \quad (11)$$

Snow intensity, S , is the fundamental parameter used to locally describe the snow. Its measurement is carried out in meteorological station.

Characteristics of snow precipitation are derived from those of rain precipitation in the altitude function system. A weighting coefficient, function of altitude (km), is applied to rain rainfall rate, R_p , exceeded for any given percentage, p , of the average year for any location (Fig. 6). Knowing the link margin deduced from the optical power link budget, we can deduce, by dichotomy, the interruption probability of the link due to snow.

FIGURE 6
Snow/rain weighting coefficient in function of altitude

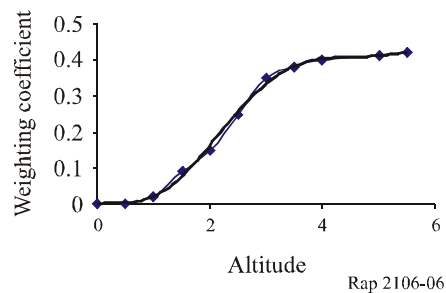

Example:

Altitude = 147 m, $\lambda = 850$ nm, $S = 40$ mm/h

$$Att_{snow} = ((0.0001023 \times 850) + 3.7855466) \times 40^{0.72} = 55.14 \text{ dB/km}$$

$$Att_{snow} = 55 \text{ dB/km.}$$

3.5 Ambient light attenuation

Solar conjunction occurs when the sun or a reflected image of the sun is in or near the instantaneous field of view of an optical receiver, F_v . The receiver is generally at least as large as the transmit divergence. Here we will calculate the probability for which the sun position is parallel to the optical link and the sun power penetrating inside the receiver is greater than the power received from the transmitter.

3.5.1 Solar trajectory

The following Fig. 7 schematically represents the geometrical aspects of the sun path in the sky with regard to a FSOL (A is the receiver, B the transmitter).

FIGURE 7
Schematic sun path with regard to a FSOL

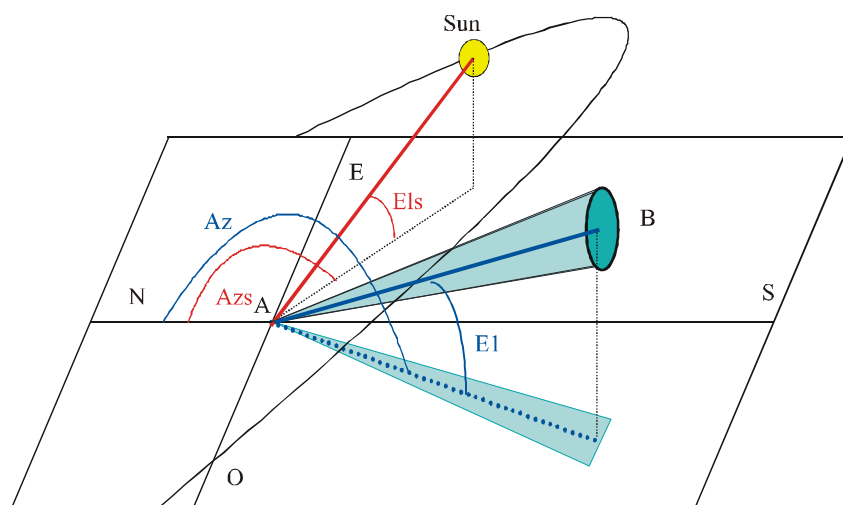

Rap 2106-07

The different sun parameters (height, azimuth) are deduced for each day of the year, each hour, minute and second from its declination and its right ascension.

3.5.2 Solar power at the receiver

The power radiated by the sun (W/m^2) is defined by the following equation:

$$\text{Power_radiated} = 1200 * \cos\left(\frac{\pi}{2} - \text{Elevation}_{\text{radian}}\right) \quad (12)$$

where:

Elevation_{radian}: sun height.

The power penetrating inside the receiver is given by the following equation:

$$P_{\text{solar}} = F_{\text{solar}} * \text{Power_radiated} * \text{Capture_surface} * \text{Width_band}_{\text{receiver(nm)}} / 100 \quad (13)$$

where:

F_{solar} : wavelength function characterizing the sun spectral-power

Capture_surface: capture surface receiver

Width_band_{receiver(nm)}: width band receiver.

3.6 Scintillation effects

Under the influence of thermal turbulence within the propagation medium one attends the formation of random, variable size (10 cm – 1 km) and of different temperature cells. These various cells have different refraction indexes thus causing scattering, multiple paths and arrival angle variations: the received signal quickly fluctuates at frequencies ranging between 0.01 and 200 Hz. The wave front varies in a similar way causing focusing and defocusing of the beam. Such signal fluctuations are called scintillations. Scintillation amplitude and frequency depend on the cells size compared to beam diameter. When heterogeneities are large compared to the beam cross section, it is deviated, when they are small, the beam is widened.

The tropospheric scintillation effect is generally studied starting from the logarithm of the amplitude χ (dB) of the observed signal (“log-amplitude”), defined as the ratio in decibels of its instantaneous amplitude and its average value. Intensity and speed of the fluctuations (frequency of scintillations) increase with the wave frequency. For a plane wave, a weak turbulence and a specific receiver, the scintillation variance σ_χ^2 (dB²) can be expressed by the following relation:

$$\sigma_x^2 = 23.17 * k^{7/6} * C_n^2 * L^{11/6} \quad (14)$$

where:

- k (m⁻¹): wave number $\frac{2\pi}{\lambda}$
- L : link length (m)
- C_n^2 (m^{-2/3}): structural parameter of the refraction index representing the turbulence intensity. It is a function of roughness, solar radiation, humidity and terrestrial albedo.

Scintillation peak-to-peak amplitude is equal to $4\sigma_\chi$ and attenuation related to scintillation is equal to $2\sigma_\chi$. For strong turbulences, one observes a saturation of the variance given by the relation above [13]. One will note that C_n^2 parameter does not have the same value at millimetre and optical wavelength [14]. Millimetre waves are especially sensitive to humidity fluctuations while in optic, refraction index is a primarily function of the temperature (the water vapour contribution is negligible). One obtains in millimetre waves a value of C_n^2 of about 10^{-13} m^{-2/3} what is an average turbulence (in general into millimetre we have $10^{-14} < C_n^2 < 10^{-12}$) and in optics a value of C_n^2 about 2×10^{-15} m^{-2/3} what is a light turbulence (in general in optics we have $10^{-16} < C_n^2 < 10^{-13}$) [13].

3.7 Other factors

In outdoor propagation, FSOL scarcely incurs any background noise. However, FSOL may be interrupted by the sunray, when it comes across the receiving beam direction of the FSOL. In case that the sunray intersects the main axis of the receiving beam, the condensed thermal effect of the lens may become so significant as to destroy the receiver. Direction of the optical link should be selected to avoid the sunray intersection.

4 Applications in the fixed service

4.1 General features

FSOL has the following advantages:

- broadband or high data rate;
- small and simple equipment;
- license-free operation;
- advantageous cost;
- fast and simple deployment;
- quick link reuse and relocation.

For some specific applications, the FSOL offers several additional advantages to the ones offered by a traditional fixed link or those based on optical fibre. Below are some examples of possible applications:

- a link for a special event;
- a temporary link: a quick installation for a limited time in order to wait for a definitive traditional link;
- an emergency link: installation of an emergency link in case of a broken link;
- intersite link, independent network (PDH, SDH, ATM, Ethernet 10/100/1 000);
- optical ring close;
- backup link;
- dense network;
- mobile infrastructure, e.g. GSM or IMT-2000 nanocell or picocell link.

And FSOL has the following disadvantages:

- availability related to the distance;
- LoS condition.

On the other hand, optical wave transmission over the free space has to overcome some problems due to propagation as discussed in § 3.

4.2 Basic application examples

Making use of the advantages, typical FSOL applications are realized in limited distance. This paragraph presents examples of local area network (LAN) connection link between the buildings and a connection for the mobile infrastructure extension as shown in Figs. 8 and 9.

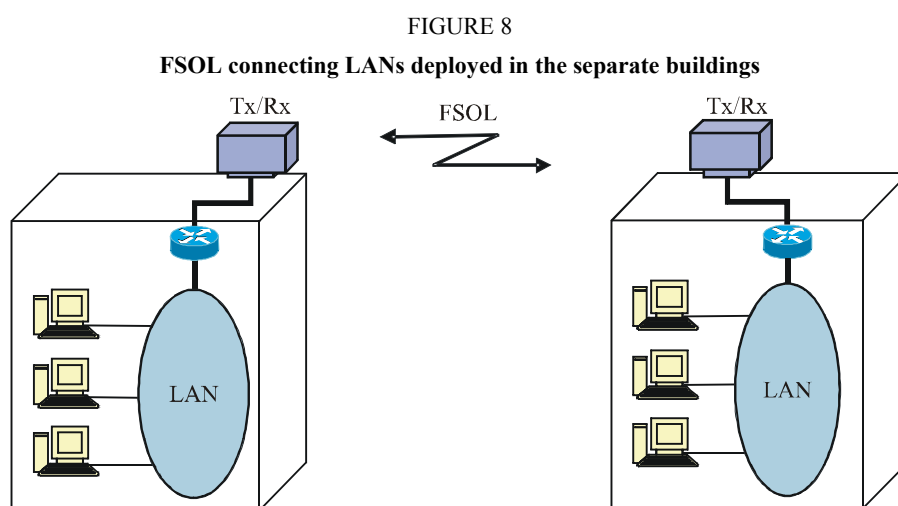

Rap 2106-08

FIGURE 9
FSOL extending mobile infrastructure

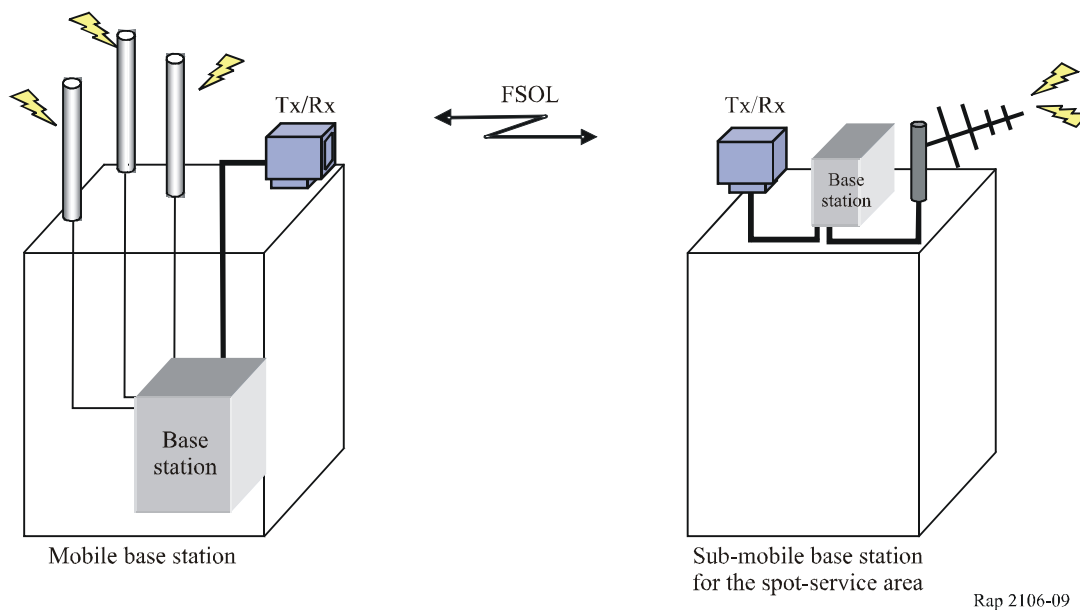

4.3 Real deployment examples

This paragraph provides a FSOL deployment example forming broadband local network solution in conjunction with optical fibre systems.

Figure 9 illustrates configuration of the school network intended for high-speed Internet access, using FSOL in combination with the fibre systems. Such broadband network infrastructure has been deployed in many schools utilizing various transmission media ranging from satellite, optical fibre, fixed wireless access to FSOLs. In Japan FSOL is used in links to more than 100 schools.

There are cases that one building is used for relay facility to provide extended links to more than one school. Such branching is easily realized using the same frequency/wavelength signal. The system parameters for the FSOL in Fig. 10 are given in Table 2.

TABLE 2
FSOL parameters

Maximum link length (km)	Around 2 ⁽¹⁾
Transmission capacity (Mbit/s)	300
Margin for attenuation (dB)	20
Optic device (wavelength range)	Laser diode/Si-APD (0.8 μm band)
Cable interface	Optical fibre 1.3 μm

⁽¹⁾ Link availability of above 99%

APD: avalanche photo diode

The link availability of the FSOL is designed based on visibility statistics data accumulated by the local meteorological authority (see § 3.2.1).

FIGURE 10
Deployment example of broadband school network using

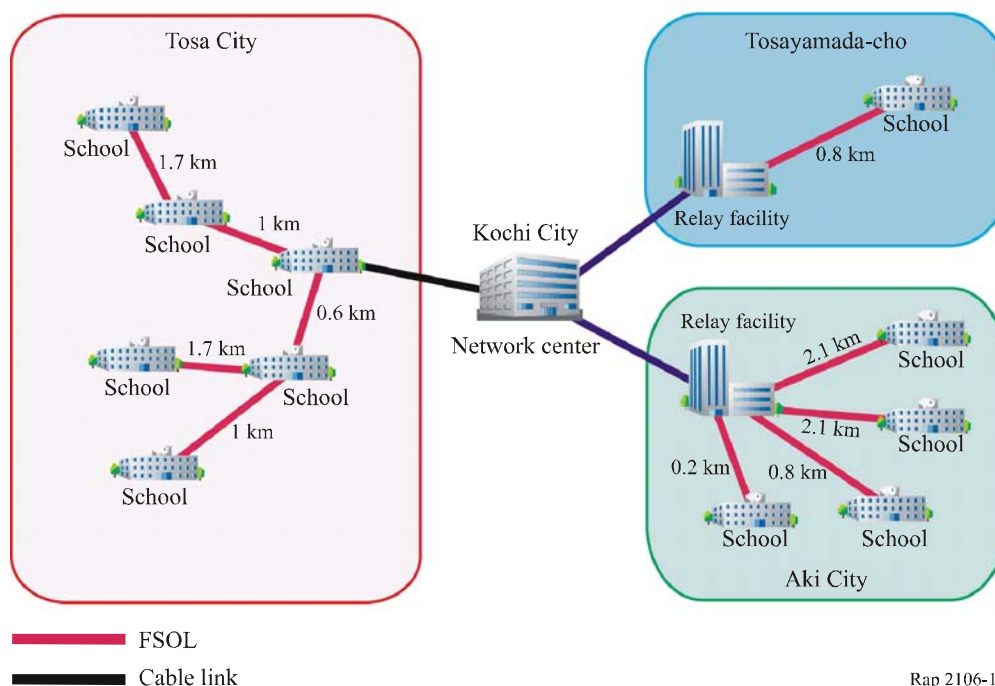

Rap 2106-10

5 Link design consideration

5.1 Link margin

One of the important elements to know in FSO transmissions is the link margin of the laser. To use the prediction models, the necessary parameters of the equipment are (non-exhaustive):

- the transmit power;
- the sensitivity of the receiver;
- the capture area of the receiver;
- the divergence of the transmit beam.

The optical link margin is the power available above the sensitivity of the receiver. The following relation defines it:

$$M_{link} = E_p + |S_s| - Att_{Geo} - Att_{mol} - Sl \quad (15)$$

where:

- M_{link} : link margin (dB)
- E_p : power of the emission signal (dBm)
- S_s : sensitivity (dBm)
- Att_{Geo} : geometrical attenuation of the link (dB)
- Att_{mol} : molecular attenuation of the link (dB)
- S_{loss} : equipment loss of the equipment (dB) given by the manufacturer (possibly multiplied by 2, supposed to be 0 dB).

Example:

$$\begin{aligned}
 d &= 271 \text{ m}, \theta = 4 \text{ mrad}, E_p = 12 \text{ dBm}, S_s = -50 \text{ dBm} \\
 Att_{Geo} &= 21 \text{ dB} \\
 Att_{mol} &= 0.11 \text{ dB} \\
 S_{loss} &= 0 \text{ dB} \\
 M_{link} &= 12 + |-50| - 21 - 0.11 - 0 = 40.89 \\
 M_{link} &= 41 \text{ dB.}
 \end{aligned}$$

In the following paragraph, the different fixed attenuations are described and have to be taken into account when calculating the link margin and some other values to be known.

If there is a WDM transmission, in order to multiply the data rate transmission on the same FSOL, it could be easier to use the here-upper relation for one wavelength.

5.1.1 Spot diameter

The spot distance is the wavelength front surface at “ d ” distance according to a considered beam divergence and gives by the following relation:

$$S_d \approx d \times \tan(\theta) \quad (16)$$

where:

- θ : beam divergence (full angle) (rad)
- d : link distance (m)
- S_d : d distance spot diameter (m).

Example:

$$\begin{aligned}
 d &= 271 \text{ m}, \theta = 4 \text{ mrad} = 0.004 \text{ rad} \\
 S_d &= 271 \times \tan(0.004) = 1.084 \\
 S_d &= 1.084 \text{ m.}
 \end{aligned}$$

5.1.2 Geometrical attenuation

The beam sent by the transmitter being diverging (1-3 mrad), the receiving cell will collect only a part of the transmitted energy. The following relation gives the geometrical attenuation:

$$Att_{Geo} = \frac{S_{surf}}{S_{capture}} = \frac{\pi}{4} \frac{(d\theta)^2}{S_{capture}} \quad (17)$$

where:

- S_{surf} : spot surface at the distance d
- $S_{capture}$: receiver area surface (Ra)
- θ : beam divergence (Bd)
- d : transmitter-receiver distance.

Example:

$$\begin{aligned}
 S_d &= 0.92 \text{ m}^2, Ra = 0.00785 = 7.85 \times 10^{-3} \text{ m}^2 \\
 Att_{Geo} &= 10 \log_{10} (0.9228 / 0.00785) = 20.70 \text{ dB} \\
 Att_{Geo} &= 21 \text{ dB.}
 \end{aligned}$$

In dB, the attenuation is given by:

$$Att_{dB} = 10 \log_{10}(Aff) \quad (18)$$

5.1.3 Molecular attenuation

The molecular attenuation (O₂, H₂, CO₂, O₃, ...) is a well known part of the atmospheric attenuation and is part of the function of the used wavelength. Some typical values (linear value) are given in the Table 3:

TABLE 3
Molecular attenuation typical values

Wavelength (nm)	Att_{lin} = Specific molecular attenuation (dB/km)
550	0.13
690	0.01
780	0.41
850	0.41
1 550	0.01

And the following relation gives the molecular attenuation for a considered distance link:

$$Att_{mol}(dB) = Att_{lin}(\lambda) * d \quad (19)$$

where:

Att_{lin} : lineic molecular attenuation
 d : transmitter-receiver distance

Example:

$$\begin{aligned} d &= 271 \text{ m, } \lambda = 850 \text{ nm so } Att_{lin} = 0.41 \text{ dB/km} \\ Att_{mol} &= 0.271 \times 0.41 = 0.111 \text{ dB} \\ Att_{mol} &= 0.11 \text{ dB.} \end{aligned}$$

5.1.4 Received level

The received level is the power level received by the receiver at a given distance and this value is important for the installation process. It is given by the following equation:

$$R_{level} = Ep - Att_{Geo} - Att_{mol} - S_{loss} \quad (20)$$

where:

R_{level} : received level (dBm)
 Ep : power of the transmit signal (dBm)
 Att_{mol} : molecular attenuation of the link (dB)
 S_{loss} : equipment loss of the equipment (dB) given by the manufacturer (possibly multiplied by 2, supposed to be 0 dB).

Example:

$$\begin{aligned}
 d &= 271 \text{ m}, \theta: 4 \text{ mrad}, Ep: 12 \text{ dBm}, Ss: -50 \text{ dBm} \\
 Att_{Geo} &= 21 \text{ dB} \\
 Att_{mol} &= 0.11 \text{ dB} \\
 S_{loss} &= 0 \text{ dB} \\
 R_{level} &= 12 - 21 - 0.11 - 0 = -9.11 \text{ dBm} \\
 R_{level} &= -9 \text{ dBm}.
 \end{aligned}$$

5.1.5 Wavelength front beam homogeneity

One of the influences of the wavelength front beam homogeneity is the quality of the sources and the optics used. These elements give on the spot projected quality and thus on the link assessment. The ideal objective is to achieve a uniform spot with a homogeneous distribution of the power (Top Hat) and the difference power on the wavelength front beam should not exceed 3 dB. Figure 11 shows various spots and homogeneities.

FIGURE 11
FSO various spots and homogeneities

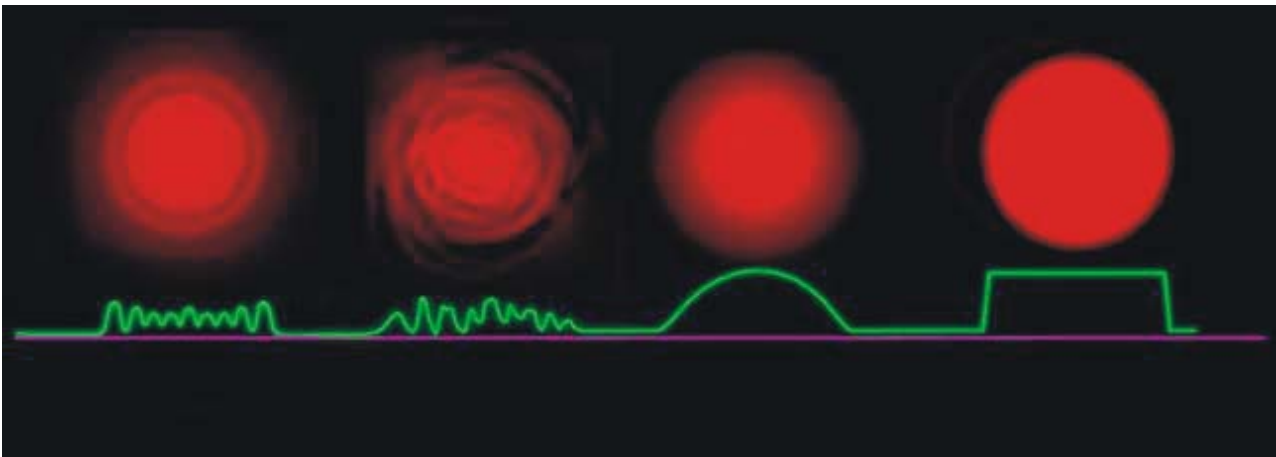

Rap 2106-11

5.1.6 Margin for the unit distance

For a considered link with a given distance, one of the important elements (but not the only one) to know is the margin for the unit distance in order to have one of the terminal comparison elements. And the following relation defines it:

$$L_{margin}(\text{dB/km}) = M_{link} / d \quad (21)$$

where:

- L_{margin} : margin (dB/km) for the unit distance
- M_{link} : link margin (dB)
- d : distance (km)

Example:

$$d = 0.271 \text{ km}, M_{link} = 41 \text{ dB}$$

$$L_{margin} = 41/0.271 = 151.29 \text{ dB/km}$$

$$L_{margin} = 151 \text{ dB/km.}$$

6 Deployment of FSOL in specific climatic areas

As mentioned in the previous section, FSOL usually requires fairly large margin against rainfall and fog. If it is deployed in almost rain-free areas, link length will be much increased. It is assumed that, from a simple calculation, exemption of 20 dB margin will result in a 10 times longer link. In such a case, however, effects of the atmospheric attenuation L_{atm} (see § 3.1) as well as impact of optical beam bending have to be taken into account. These effects mainly caused by the molecule absorption or atmosphere refraction due to the temperature variation could be observed in scintillation fading i.e. fluctuation of the received level. The extent of the fluctuation in the desert, which is defined by equation (14) in § 3.6, needs further study. However, for semi-arid regions, Zilbermann *et al.* [12] have developed a Middle East vertical profile model of the refractive turbulence strength C_n^2 based on a large set of imaging LIDAR measurements. This model can be applied to desert areas until a more consolidated model is proposed in the future.

As a measure to overcome this type of scintillation fading, diversity reception may be effective using separate lens arrangement.

Another issue to be considered is the effects of sandstorms in the desert, which may significantly obstruct visibility condition over a hop between the transmitter and the receiver. Dust and sand blown by the wind in the desert are composed of loose and finely grained soils (e.g. calcium, silicon, aluminium and sulphur). Effect of sandstorm on the visibility of FSOL depends on the wind speed. Although there is a certain computer program available to calculate the total (absorption and scattering) transmission coefficient in a desert area, this issue has not yet been fully investigated and may also require further study.

However, for the present time the FASCOD computer program (from ONTAR) using the desert model (where aerosols are essentially suspended sand particles) can be used to calculate the total (absorption and scattering) transmission coefficient in a desert area. The necessary input data are the visibility at the ground level and the wind speed at 10 m height. The user is able to define its own climatic and aerosol model to calculate the atmospheric attenuation, or use the measurements of aerosol size distribution, volume and number concentration obtained by Zilbermann and Kopeika [12] from LIDAR measurements at different heights in the Mediterranean region (Israel).

7 Consideration on the operational aspect

Optical links are deployed at any time and any place. This is based on the assumption that there is no possibility requiring coordination to avoid interference between such links operated by different operators.

Theoretically, interference between FSOLs may occur under the following environments:

- when two systems are using the same frequency (wavelength), or mutually close frequencies (wavelengths);
- and at the same time, they are operating within a geographically close separation.

When the used frequencies are mutually close, transmitted spectrum of an optical wave may overlap with another FSOL spectrum, causing unacceptable interference. In that sense, choice of the frequencies (wavelengths) may be a matter of consideration by the operators to avoid effect of the interference between FSOLs (see § 2.3).

However, the interference will never have harmful effect unless two links operate under a quite limited geographical environment. As mentioned in § 3.1, light wave beam spot at the receiving side is usually adjusted so that its diameter is around several metres for a link length of about 1 km. This means that the transmitted power of FSOL is very much concentrated in the sharp beam with an aperture angle of the order of 0.1° . On the other hand, the lens aperture at the receiver side has a slightly wider angle to flexibly adapt to building rock or other factors of unstableness. It should be noted that the optical wave power will be significantly reduced, e.g. by several tens dB, outside the receiving beam spot.

It is, therefore, assumed that, there is little possibility of an interference problem between different operator's FSOLs unless they are deployed almost in parallel using the same frequency (wavelength).

The sunray effect discussed in § 3.7 may need more attention of the operators for site selection of the FSOL stations.

7.1 Propagation times

Another interesting characteristic of FSO equipment is its digital data transmission speed ; which possibly allows to cast off the router for a LAN link for instance.

Indeed, the majority of FSO equipment is transparent to the transmitted protocol. Generally, no treatment is carried out on the contents or the nature of the data, which offers relatively short propagation times.

The parameters to be taken into account in the calculation of the propagation time to the access are:

- electronic processing time of the FSO equipment (transmitter and receiver);
- the propagation time of the light in the atmosphere between A and B equipments (propagation time of the light in the atmosphere: about 3×10^{-9} s/m);
- the propagation time to the access is the sum of these two parameters;
- example:
 - 500 m links,
 - 155 Mbit/s data rate,
 - example electronic processing time of FSO equipment: $3 \times 10^{-7} \times 2 = 6 \times 10^{-7}$ s;
 - the propagation time of the light in the atmosphere between A and B equipments: $500 \text{ m} \geq \text{propagation time } 1.5 \times 10^{-6} \text{ s}$;
 - the time of propagation is: $6 \times 10^{-7} + 1.5 \times 10^{-6} = 2.11 \times 10^{-6} \Leftrightarrow \text{let } 2.11 \text{ } \mu\text{s}$.

7.2 Transmitted data confidentiality

The majority of the manufacturers use a “one-off” type amplitude modulation for data transmission by laser, the transmission protocol is generally transparent, but the possibilities of “hacking” information are rather restricted.

Apart from any direct action on the equipment or its accesses, there are only two solutions for a person “to recover” the transmitted data, with important technical skills and complex interventions criteria.

Information hacking is only possible if the person carries out the following operations:

- 1 Obtain the same FSO equipment from the same manufacturer, to collect and to decode data.
- 2 Carry out data “collecting”, a part of the beam, which is, nevertheless, very directional. And ”recovers” sufficient energy to-process them (Fig. 12):
 - either between the two sites, A, to obtain the data transmitted from site X or Y only, with an additional difficulty which consists of avoiding cutting the beam,
 - or, for example, behind the Y site, B, for the data transmitted from site X, knowing that the signal attenuation is very important as one moves away from the source.
 - or, for example, in front of the equipment of the Y site, B, for the data transmitted from the site Y, with an additional difficulty which consists of avoiding cutting the beam.
- 3 Finally, the last difficulty consists of knowing the transmitted protocol, in order to understand the collected data.

FIGURE 12

To collect bits transmitted by sites X or Y, the hacker must collect a part of the beams

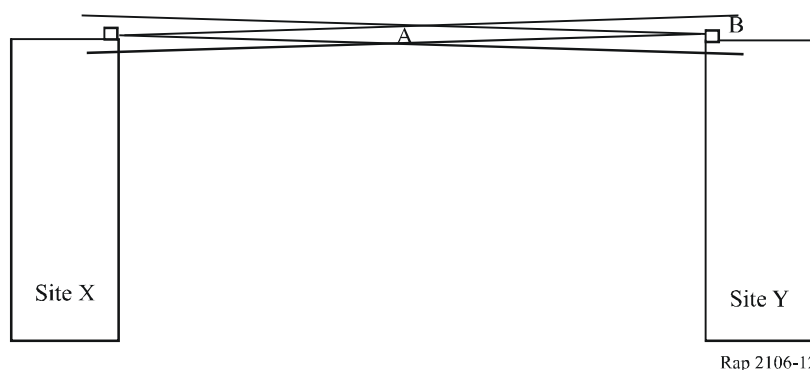

Rap 2106-12

7.3 Guidelines for implement FSOL

7.3.1 FSO installation process

Generally, FSO equipment is set up in a similar way to a fixed wireless system:

- link engineering process (for instance; with the “FSO prediction” software) in order to define the link availability;
- installation on a high point (building, pylon, water tower, ...);
- in LoS with no obstacles on the actual or future trajectory;
- installation time lower than one day for a link.

But due to this specific technology, some elements and precautionary measures, are to be taken into account during the installation process (Fig. 13).

FIGURE 13

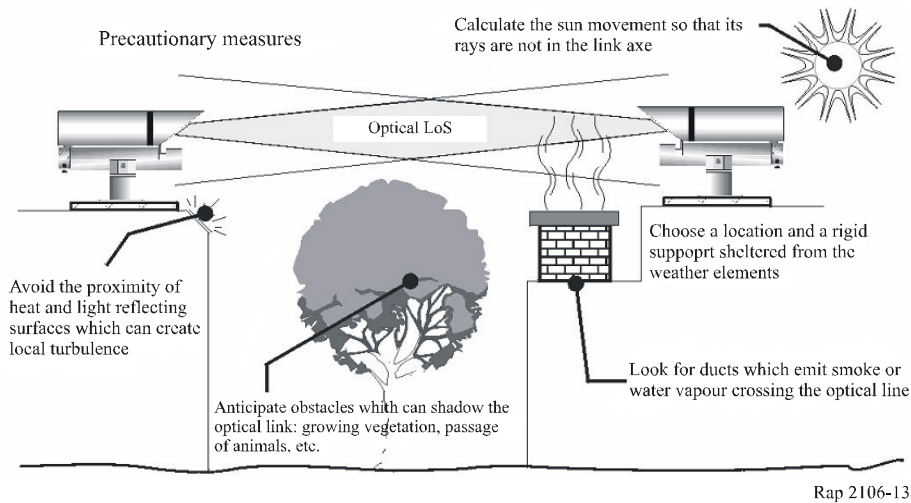
FSO installation precautionary measures

With the characteristic of the equipment (low divergence of the laser beam) being given, a very precise alignment is necessary. The alignment of the transmitter and the receiver characterizes the coupling of the optical link. These can be disturbed following mechanical vibrations. The fitter of the communication system must:

- fix the materials on a rigid support or a load-bearing wall so that it is subject to less possible vibrations or shock (edge of wall, side of wall, ...);
- avoid the direct alignment of optics with the rays of the sun;
- avoid the proximity of elements that can carry away atmospheric turbulence (chimney, reflective surface, ...).

7.3.2 FSO alignment process example

An FSO alignment process can be done with some preliminary calculated values, such as:

- received level;
- spot diameter.

The first alignment level is achieved by using visual rise and azimuth alignment on both sides.

And the accurate alignment should be held by camera, sound level, bip frequency, power meter indication and should follow these steps (Figs. 14 and 15).

FIGURE 14
Alignment process example

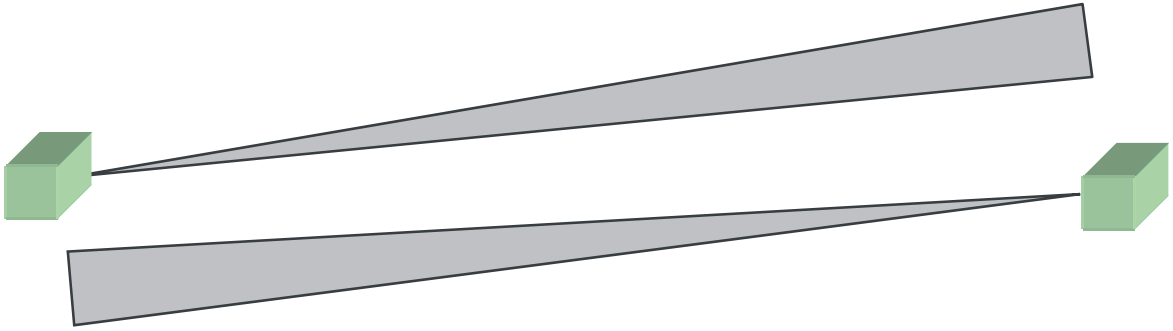

a) Side 1 FSO beam alignment to side 2 FSO receiver

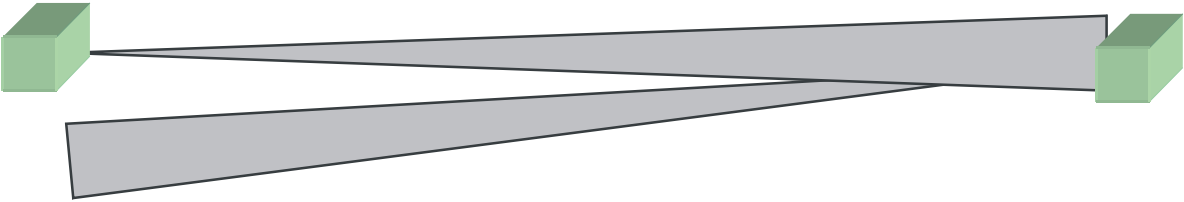

b) Side 2 FSO beam alignment to side 1 FSO receiver



c) Additionally, wavelength front beam fine centring from site 1 (purple) compared to the receiver area (Ra) (red) of site 2 and vice versa (in rise and azimuth)

Rap 2106-14

FIGURE 15
Fine process alignment process

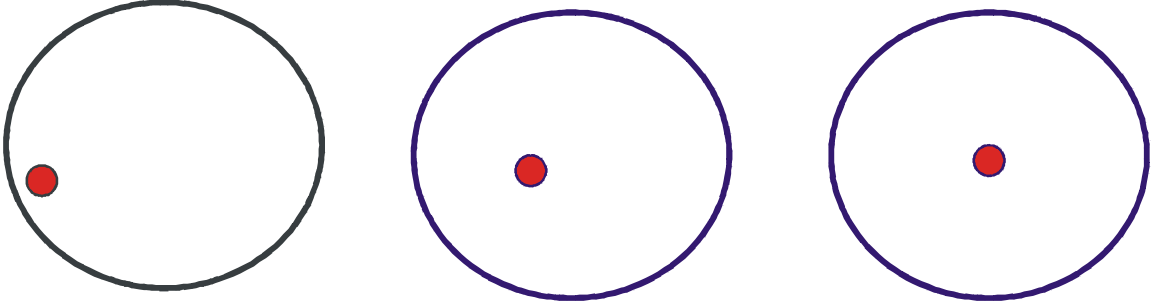

Rap 2106-15

7.4 Multi FSOLs

In case of a multi-FSOLs implemented with the same wavelength and the same reception level, the following care should be taken to avoid the error bit:

- minimum spot diameter separation between the two parallel or nearly parallel FSOLs should be twice more important than a shorter distance spot diameter FSOL;
- minimum angular separation between two FSOLs should be twice as important as the shorter distance full angle divergence FSOL;
- it should be noted that the ITU-T SG 15 has developed ITU-T Recommendation G.640 on this item – Colocation longitudinally compatible interfaces for free-space optical systems.

8 Summary

This Report considers characteristics of FSOLs for FS applications as well as their technical/operational requirements. Consideration given in the previous sections focuses on FSOL for fixed service applications, and it is noted that there are other types of FSOL, e.g. belonging to the mobile service or space services. Items requiring further study or to be taken into account could be summarized as follows;

- technology development trend in the optical devices;
- expansion of FS applications;
- compatibility, if necessary, with FSOLs for other radiocommunication service applications.

Future study may extend the FSOs to multipoint FSO outdoor systems, point-to-point and point-to-multipoint FSO indoor systems, and test and measurement processes.

References

- [1] G. Nykolak, *et al.*, “4 X 2.5 Gb/s 4.4 km WDM free-space optical link at 1 550 nm,” in Proc. OFC’99, PD11, 1999.
- [2] Y. Aburakawa, “Dense wavelength division multiplexed optical wireless link towards terabit transmission,” in Proc. Of MWP’03, pp. 135, 2003.
- [3] International Electrotechnical Commission (IEC), IEC 60825-1 standard, “Safety of laser products”.
- [4] G. Mie, Ann. Physik., Vol. 25, pp. 377-445, 1908.
- [5] K. Morita, *et al.*, “Light wave attenuation in propagation through the atmosphere,” Review of Electrical Communications Labs., Vol. 19, No. 714-725, pp. 798-842, 1971.
- [6] Final Approach Visibility Studies, 1955, U.S. Weather Bureau.
- [7] Y. Aburakawa, *et al.*, “Experimental evaluation of 800-nm band optical wireless link for radio access network,” IEICE Trans. Electron., Vol. E86-C, pp. 1 175-1 183, No. 7, 2003.
- [8] J.S. Marshal and W.M. Palmer, “The distribution of raindrops with size”, Journal of the Meteorology, Vol. 5, No. 6, pp. 165, 1948.
- [9] K. Morita, and I. Higuchi, “Statistical studies on electromagnetic wave attenuation due to rain,” Review of Electrical Communications Labs., Vol. 19, No. 7-8, pp. 798-842, 1971.

- [10] N. Hiromoto, "Novel detector technologies for infrared communication and sensing, CRL International Topic Workshop on Space Laser Communication Current Status and Future Perspectives, pp. 90-95, 1997.
- [11] M. Akiba, *et al.*, "Measurement of optical propagation characteristics for free-space optical communication during rainfall", IEICE Trans. Commun., Vol. E87-B, No. 7 July 2004.
- [12] Zilberman A., Kopeika N. S., "Aerosol and turbulence characterization at different heights in semi-arid regions", Proc. SPIE Vol. 5891, p. 129-140.
- [13] P. Bataille, "Analyse du comportement d'un système de télécommunication optique fonctionnant à 0,83 micron dans la basse troposphère", Thèse, Université Rennes, 1992.
- [14] H. Vasseur, *et al.*, "Influence de la troposphère sur les liaisons sans fil aux ondes millimétriques et optiques", Propagation électromagnétique du décimétrique à l'angström, 3ièmes journées, Rennes 1997.
- [15] T.H. Carbonneau, D.R. Wiseley, "Opportunities and challenges for optical wireless; the competitive advantage of free-space telecommunications link in today's crowded marketplace", SPIE Conf. on optic. Wireless Com., Boston, USA, Vol. 3232, 1998.

Annex 1

Examples of the link budget

1 Example of the link budget

Link budget design for FSOL is derived basically from required link availability taking into account the propagation characteristics of the location where the link is deployed.

Table A1-1 indicates examples of system parameters for two different types of FSOL. For both systems, a laser diode (LD) with the same transmit power has been adopted. Also the beam spreading loss, L_p , is selected to be an equivalent value of 24 dB. Beam spreading loss corresponds to substantial link loss for the FSOL between the transmitter, Tx, and the receiver, Rx, i.e. free-space loss minus the antenna gains in case of the electrical wave. L_p is theoretically expressed by the following formula:

$$L_p = (A_r / w_r)^2 L_{atm} \quad (\text{A-1})$$

where:

- w_r : beam spot diameter of the transmitted light at the distance r (link length)
- A_r : effective aperture of the receiving lens.

These parameters, w_r and A_r , can be adjusted by the convergence function of the optical lens installed in Tx or Rx. Atmospheric loss L_{atm} is usually considered to be small as mentioned in 3.1.

The required receiving power is derived from the calculation of L_p including necessary margins for fog and rainfall effects. In the examples in Table A1-1, the total margins are designed to be around 22 dB for both types.

It is recognized that two FSOLs with different link lengths can operate in an equivalent transmit power and beam spreading loss while resulting in the quite different outage objectives.

It is noted that link outage rate of 0.1% in Type 1 may not be applicable to the public network connection, e.g. PSTN or ISDN. On the other hand, Type 2 FSOL with much lower outage rate may serve as a fixed wireless access system connected to the public core networks.

TABLE A1-1

Example of link budget design for FSOL

Parameters	Type 1	Type 2
Link length (m)	900	350
Link capacity (Mbit/s)	622.08	
Required BER	BER = 10^{-9}	
Link outage rate	0.1% (about 9 h/year)	0.004% (about 20 min/year)
Transmit power (LD output: nominal)	13 dBm (20 mW)	
Insertion loss of Tx (dB)	3	
Beam spreading loss (dB)	24	
Insertion loss of Rx (dB)	3	
Fog margin (Note 1) (dB)	14.0	15.5
Rainfall margin (Note 1) (dB)	8.0	6.5
Receiver sensitivity (dBm)	-40	

NOTE 1 – Based on statistical data observed in Tokyo [7] [9].

2 Example of FSO availability prediction

One of the important elements to know in FSO transmissions is the margin of the FSO. In fact, following the example of radio operator equipment or radio-relay systems, it is of primary importance to know the margin of a given link. When a link is installed, mathematical models allow the calculation of the availability of the link for one year or for the most unfavourable month, for instance.

The first step consists to know the link margin. This element allows to know the capacity of the laser equipment for transmitting digital data in spite of the variations of the weather conditions.

To use the prediction models, the necessary parameters of the equipment are (non exhaustive):

- the transmitted power;
- the sensitivity of the receiver;
- the capture area of the receiver;
- the divergence of the transmitted beam.

From these data, for instance, the value of the geometrical attenuation can be known as well as the link margin and finally the availability.

2.1 Some link margin

In the table below, some examples of the calculation of a link margin for three typical equipment are given. Calculations are made for a distance of 500 m and the molecular attenuation is neglected. These link margins, data given as example, are basic elements to later apprehend the laser signal attenuation by climatic phenomena (fog, rain, snow, scintillation, ...).

TABLE A1-2

Example of a three link margin

Emission power (dBm)	10	13	26
Sensitivity (dBm)	-35	-40	-36
Geometrical attenuation (dB) ($D=500$ m)	26	17	18
System loss (dB)	1	2	0
Link margin (dB)	18	34	44

2.2 Availability and Quality of Service

This part presents a concrete example of the Quality of Service (QoS) research for a given link using the characteristics of three FSO equipments.

In the example, the following elements were considered:

- link distance: 500 m;
- manufacturer: three manufacturers of different origins (A, B and C);
- equipment: a 155 Mbit/s SDH interface with optical fibre;
- model: the France Telecom models which give the attenuation by aerosols (fog) – the most disturbing attenuation for an FSOL – was applied;
- site: only one site is study, Rennes (France).

The research of QoS is a process which proceeds in three steps; thereafter, this process can be partially or completely computerized.

2.2.1 Example of minimum visibility calculation

A 500 m link with an interface of 155 Mbit/s is considered. From the linear link margin, by applying the France Telecom attenuation models, the value of the minimum visibility is determined.

TABLE A1-3

Example of three minimum visibility calculation

	Equipment A	Equipment B	Equipment C
Wavelength (nm)	690	850	1 550
Link distance (m)	500	500	500
Transmit power (dBm)	10	13	26
Sensitivity (dBm)	-35	-40	-36
Geometrical attenuation (dB)	25.94	17.4	18.59
Molecular attenuation (dB)	0.05	0.205	0.05
System losses (dB)	0	0	0
Link margin (dB)	19	35	43
Lineic margin (dB/km)	38	71	87
Value of minimum visibility (m)	470	250	210

2.2.2 Example of weather statistical data

From weather files provided by Météo France, for a city named Rennes, whose content is the percentage of hourly fog appearance, data synthesized over a long period of time; graphs presenting the cumulated percentage of fog appearance in three time periods were carried out:

- 8 a.m. to 8 p.m.;
- 8 p.m. to 8 a.m.;
- a whole day from 0 a.m. to 12 p.m.

These weather files have the following characteristics:

- hourly visibility;
- from 100 to 5 000 m;
- from 1 992 to 2 002;
- more than 73 000 observations;
- cumulated percentage of appearance;
- three hourly observation periods.

Three curves on the graph have been drawn, for which we have:

- in X-coordinate: the minimum value of visibility (m) (i.e. fog density);
- in Y-coordinate: percentage of appearances of the various minimum visibilities (%).

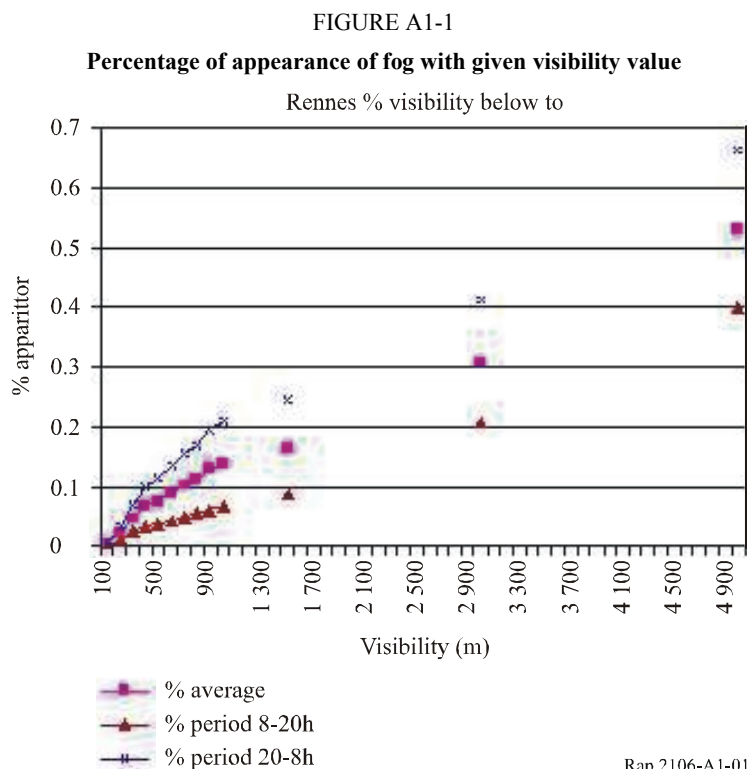

For a better legibility, the X-axis is presented in a logarithm scale.

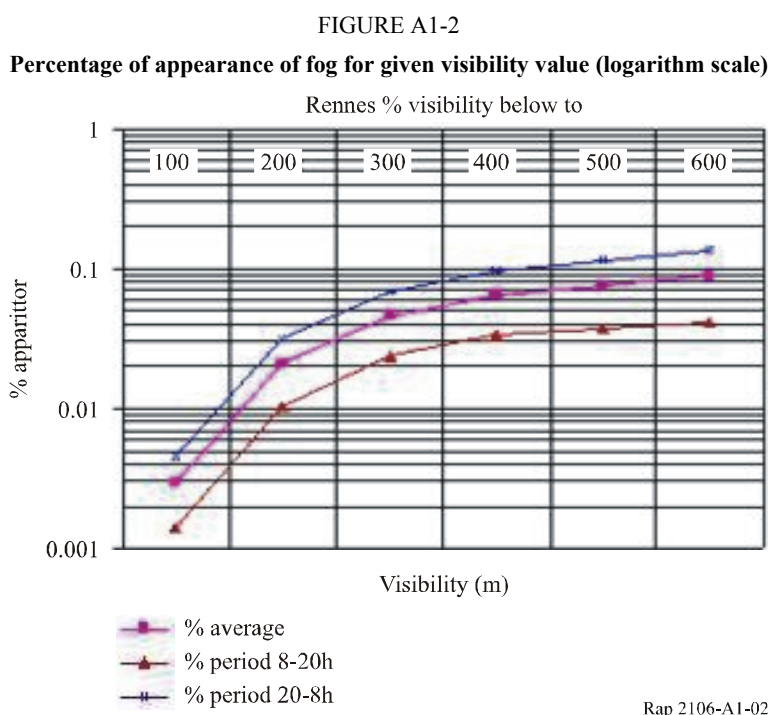

2.2.3 Example of a link availability calculation

An FSOL becomes unavailable when the fog density is higher than the link margin. Using meteorological graphs; thus the percentage of time for which we will have an unavailable FSOL is researched. By extension, the availability of the considered FSOL, expressed as a percentage and in a number of hours (or minutes) per year is determined. The research of the unavailability of an

FSOL is carried out by taking the minimum visibility value for each equipment (in X-coordinate) and by determining the percentage value of the appearance. Knowing this value, it estimates that the FSOL becomes unavailable beyond this value.

Tables below present the percentage values and the unavailability values for each piece of equipment.

TABLE A1-4
Comparison visibility and periods

% appearance		Equipment A	Equipment B	Equipment C
Minimum visibility value (m)		342	184	150
Model zoom	Day	0.052	0.015	0.008
	P8-20	0.028	0.007	0.004
	P20-8	0.08	0.022	0.012

By extension, the availability of the considered FSOL, expressed as a percentage and in a number of hours (or minutes) per year is determined. For the considered site see Table A1-5.

TABLE A1-5
Link availability on the Rennes site for three different pieces of equipment A, B and C

Equipment A	% availability	Unavailability – Nb Hours/Year
Year	99.948	4.56
8 a.m. to 8 p.m. period	99.972	1.23
8 p.m. to 8 a.m. period	99.920	3.50

8 760 hours = 1 year

Equipment B	% availability	Unavailability – Nb Hours/Year
Year	99.985	1.31
8 a.m. to 8 p.m. period	99.993	0.31
8 p.m. to 8 a.m. period	99.978	0.96

8 760 hours = 1 year

Equipment C	% availability	Unavailability – Nb Hours/Year
Year	99.992	0.70
8 a.m. to 8 p.m. period	99.996	0.18
8 p.m. to 8 a.m. period	99.988	0.53

2.2.4 Example of availability according to the link distance

Another approach consists of presenting QoS, according to the FSOL distance for the considered site.

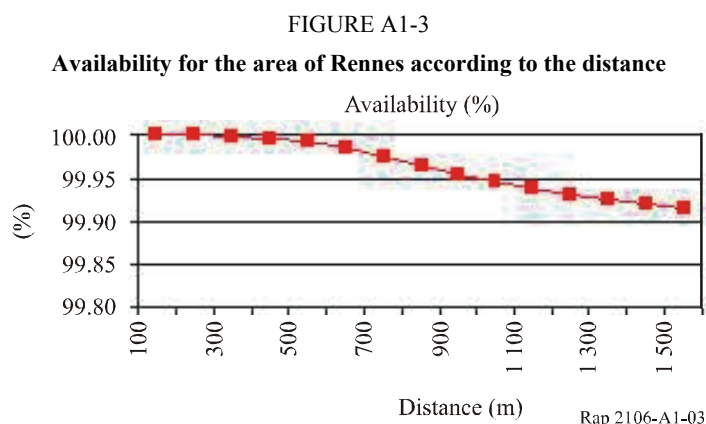

From this example, three important remarks are noted:

- QoS of an FSOL is very dependent on local weather conditions (for instance, fog) and the data-processing treatment on this climatic data becomes essential.
- QoS management is dependent on the link distance (under identical weather conditions) and a modification or an improvement on this parameter could be brought about by the equipment or the manufacturer selection. For example, from the previous graph, if a QoS higher than 99.95% in Rennes is desired; it will be necessary that the FSOL does not exceed a length of 900 m.
- This process, and other climatic parameter processes, can be computerized.

Annex 2

Comparison between ITU-R Recommendations and “FSO prediction” Quality of Service Software (Experimentation in France)

1 Introduction

An operator (FSO 04) has achieved an evaluation about FSO products capacities and developed in-house software, “FSO prediction”. To target these objectives, it was envisaged to carry out an experimentation allowing to confront the FSO equipment capacities with weather data, the study was held on a France Telecom site around Toulouse, over an approximately six month period (12.01.2004 – 31.05.2005), during the winter season, the worst season for a product using the FSO technology to transmit numerical data.

Two objectives are defined:

- To confront the “FSO prediction” software results with the data field experimentation, over one sufficiently long period, in order to release from the relevant statistical data.
 - Statistical analyse mainly directed towards the most inauspicious phenomenon of an optical link, i.e., fog attenuation or atmospheric attenuation.
 - To check the results coherence with the others attenuation phenomena and from the field test data.
- To confront the FSO link results with the ITU-R Recommendation objectives, based on a microwave link:
 - Recommendation ITU-R F.1703 – Availability objectives for real digital fixed wireless links used in 27 500 km hypothetical reference paths and connections.
 - Recommendation ITU-R F.1668 – Error performance objectives for real digital fixed wireless links used in 27 500 km hypothetical reference paths and connections.

After a brief presentation about the experimentation site characteristics and FSO equipment, a short introduction of FSO prediction, software of quality of service simulation of an optical link, developed by France Telecom Research & Development is carried out.

The software results are then compared with the optical link data and the weather data, during the considered period, in order to achieve the two objectives.

2 FSOL field test

2.1 Site and equipment characteristics

FIGURE A2-1
Link characteristics

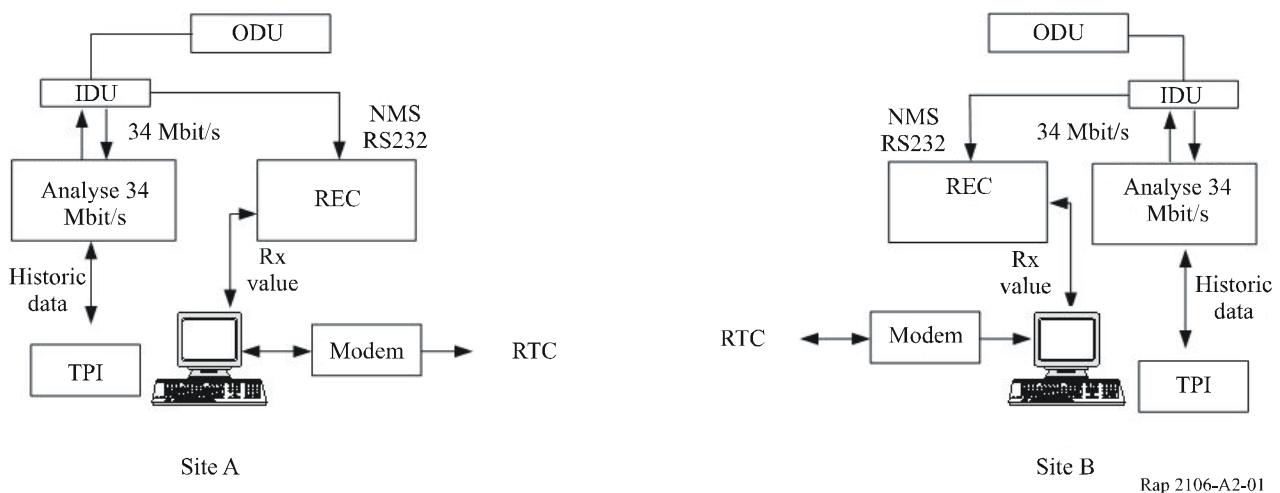

Rap 2106-A2-01

Equipments description, on each site:

- The FSO (ODU – Outdoor unit and IDU – Indoor unit) transmits PDH bilateral frame at a distance of approximately 270 m (0.2 mile) between two buildings named A and B.

- The PDH frame transmission analyser, named Victoria, records each second, the possible errors or unavailability and transmits the results to a PC every 15 min via an RS-232 connection. It is a bilateral analysis. Among the recorded data, we select and concatenate:
 - ES: errored second (bit error)
 - SES: severely errored second
 - Unavailability.
- The proprietary supervision software records, during each minute, the received level (sensitivity) and transmits continuously the data towards a PC.
- A RTC modem is installed for intervention, via the PC anywhere software, in case of problem.
- Weather data come from the France weather station located at the Blagnac airport (less than 500 m, around 0.4 mile, from the France Telecom experimentation site). The data are transmitted, each week, by E-mail and are defined by following measurements:
 - Transmissometer, giving the visibility value (All values – frequency: each – minute – approximately 40 000 monthly values).
 - Pluviometer, giving the precipitation intensity (maximum value – frequency: every 6 min).
 - Snow, giving the snow intensity (maximum value).
 - Pyranometer, giving the light intensity (maximum value).

2.2 Link design

2.2.1 Engineering data

The FSOL is made of two terminal equipments (each with ODU and IDU) pointing at each other and offering a PDH bilateral connection at a distance of approximately 270 m. Several information are essential [BOU 06] within the framework of the installation link, the information are:

- the link margin,
- the received level,
- the spot diameter.

2.2.2 Field data

After the installation process, the link measured data, in each direction, are presented in Tables A2-1 and 2:

TABLE A2-1
Sensitivity A to B

Direction: From A to B	Received level	Theoretically	–9 dBm
		Real	–11 dBm⁽¹⁾
	Link margin	Theoretically	41 dB
		Real	39 dB

⁽¹⁾ The 2 dB difference can possibly be decreased by a finer pointing.

TABLE A2-2
Sensitivity B to A

Direction: From B to A	Received level	Theoretically	-9 dBm
		Real	-16 dBm⁽¹⁾
	Link margin	Theoretically	41 dB
		Real	34 dB

⁽¹⁾ The 5 dB difference between the two directions is voluntarily maintained, in order to study the margin sensitivity compared to the criteria of availability and quality of service.

3 Simulation software

Software FSO prediction V3.00 allows:

- The optical link design calculation, for any geographical place.
- The availability calculation of this link, for any place in France (in this version).

3.1 Capture data window

From the site data and FSO equipment measurements, we write these values in the first window of FSO prediction software; divided into six blocks of items, data sites block, equipment block, common sites data, common equipment data, environment and information. Then we launch the computing process allowing to determine various link parameters and to define the QoS and the availability from weather files.

FIGURE A2-2
Capture data Windows

The screenshot shows the 'Capture data' window with the following fields:

- Sites data:**
 - Site 1: Name (Site A), Latitude (48.8582), Longitude (10.8245), Altitude (147), Site height (18), Site positioning (96).
 - Site 2: Name (Site B), Latitude (48.8582), Longitude (10.8245), Altitude (147), Site height (6), Site positioning (276).
- Shared site data:**
 - Relative humidity (%): 100
 - Albedo (0..1): 0.1 Grass
 - Distance (m): 271
 - Rugosity (m): 0.0045 Lawn
 - Solar radiation (W/m2): 1000
- Equipment data:**

	Emission		Reception	
Transmitter Fza	2	1	2	1
Power transmitted (dBm)	3	50	3	50
Diameter (mm)	40	100	40	100
Divergence (mrad)	4	5	4	5
Power (dBm)				
Losses (dB)	0	0	0	0
Central wavelength (nm)		955		955
Bandwidth (nm)		100		100
- Shared equipment data:**
 - Wavelength (nm): 950
 - Data rate (Mbps): 34
 - System Loss (dB): 0
- Environment:**
 - Urban (checked), Rural, Maritime
- Information:**
 - Link distance (m):
 - Link average height (m):
 - Elevation (deg):
 - Azimuth (deg):

Rap 2106-A2-02

3.2 Report window

The report window shows us:

- Availability block item
 - An availability during the year of 99.3037%, corresponding to 61 h of interruption.
 - An availability during the most unfavourable month of 96.9849%, corresponding to 22 h of interruption, it is 36% of the year interruption volume.

- An availability during the day of 99.7260%, it is 20% of day interruption volume.
- An availability during the night of 98.8813%, it is 80% day interruption volume.
- Meteorological phenomena block item
 - A fog influence, 0.696347%, it is 99.9982% of the phenomena volume.
 - An ambient light influence, 0.000012%, it is 0.0018% of the phenomena volume.
- No scintillation, nor rain and snow influence.

FIGURE A2-3
Report window

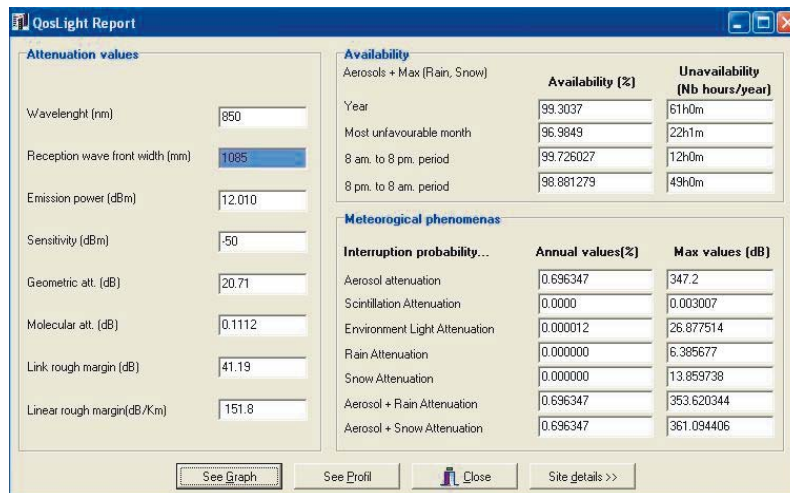

Rap 2106-A2-03

3.3 Profile window

This window stands for the two sites and the difference between the beam spot at the receiver and the receiver surface. The ratio is given by, beam spot at the receiver divided by receiver surface; and is equal to $1\ 085/100$; means 10.85. This value indicates to us:

- An important proportion allowing to achieve a pointing of the bilateral link, under good condition.
- A good resistance to the vibration or dilation phenomena of the supports (buildings).

FIGURE A2-4
Profile window

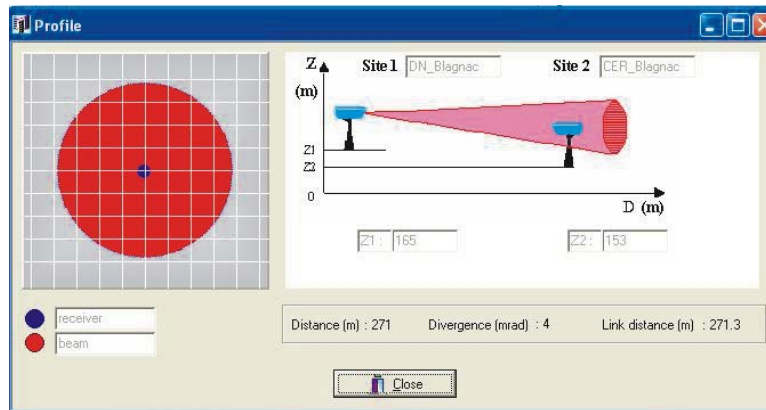

Rap 2106-A2-04

4 Results comparison

In this chapter, we carry out the process of comparison between the six months experimentation data, the criteria of availability and QoS and the values done by the software.

4.1 Comparison FSO prediction versus FSO and France weather station

4.1.1 Aerosol attenuation (fog)

Three formulas of aerosol attenuation or fog are analysed and compared, in order to check the models determined by Al Naboulsi & Al and are integrated in FSO prediction software.

Those three models are:

- Kim & Al model
- Advection Al Naboulsi & Al fog model for the day period, and
- radiation Al Naboulsi & Al fog model for the night period.

Fog radiation attenuation example (see equation (3) in § 3.2.2 in the main text)

$$Aff_{fog,d} = 10 \log_{10}(1/\tau(\lambda, d)) = 10 \log_{10}(1/\exp(-\sigma(\lambda)d)) = 10 \log_{10} \exp(\sigma(\lambda)d) = 10 \frac{\ln(\exp(\sigma(\lambda)d))}{\ln 10}$$

Is equivalent to:

$$Aff_{fog,d} = \frac{10}{\ln 10} \sigma(\lambda)d$$

For instance, with 80 m visibility fog, we have: $\sigma(850)d = 49.97$ and $Aff_{fog} = 217$ dB/km.

4.1.1.2 Process

The data are processed in order to be able to propose comparative models based on FSOL cut off. These data are selected when we have a fog (weather file – data of visibility) sufficiently intense to cut off the optical link.

For instance, a 100 m visibility fog is equivalent to an aerosol attenuation around 180 dB/km; means for the link distance, about 49 dB. This value is higher than the link margin (linear margin: 124 dB/km), we thus have, in theory, a connection cut off.

This fog cut off must be confirmed, at the same time typologies (MM:DD:YY–HH:MM) by the transmission analyser data files (link unavailability value) and the FSO supervision software data (sensitivity value – $S < -55$ dBm – cut off equivalent during the laboratory tests).

Only the data are selected for which the cut off is only due to the fog.

4.1.1.3 Results

Approximately more than 400 values, answering the characteristics described above, were selected. Some incoherent data (important visibility and operational connection) were rejected. It can be explained by the relative distance of the FSOL experimentation and the site of France weather station (500 m), which involves a light temporal shift in the recordings when the fog movement is perpendicular to the two sites; or with aberrant results when the fog movement is parallel to the two sites.

The result is presented in the graph here under:

- The optical linear link margin which is 124 dB/km (blue straight),
- The Kim & Al attenuation fog formula (red dotted curve),
- The Al Naboulsi attenuation fog formulas, associated per hour of the event for the selection of the one of the two models (green curve).

All the values presented in this graph were selected because of a very low visibility, which means a strong fog attenuation value involving an obligatory cut off of the optical link.

It appears that for a configuration of link cut off, the Al Naboulsi attenuation fog formulas present a complete coherence with the link margin (100%); while the Kim & Al attenuation fog formula is not coherent in almost 50% of the cases. The Al Naboulsi attenuation fog formulas seems to be more in accordance with the reality.

FIGURE A2-5
Fog attenuation comparison

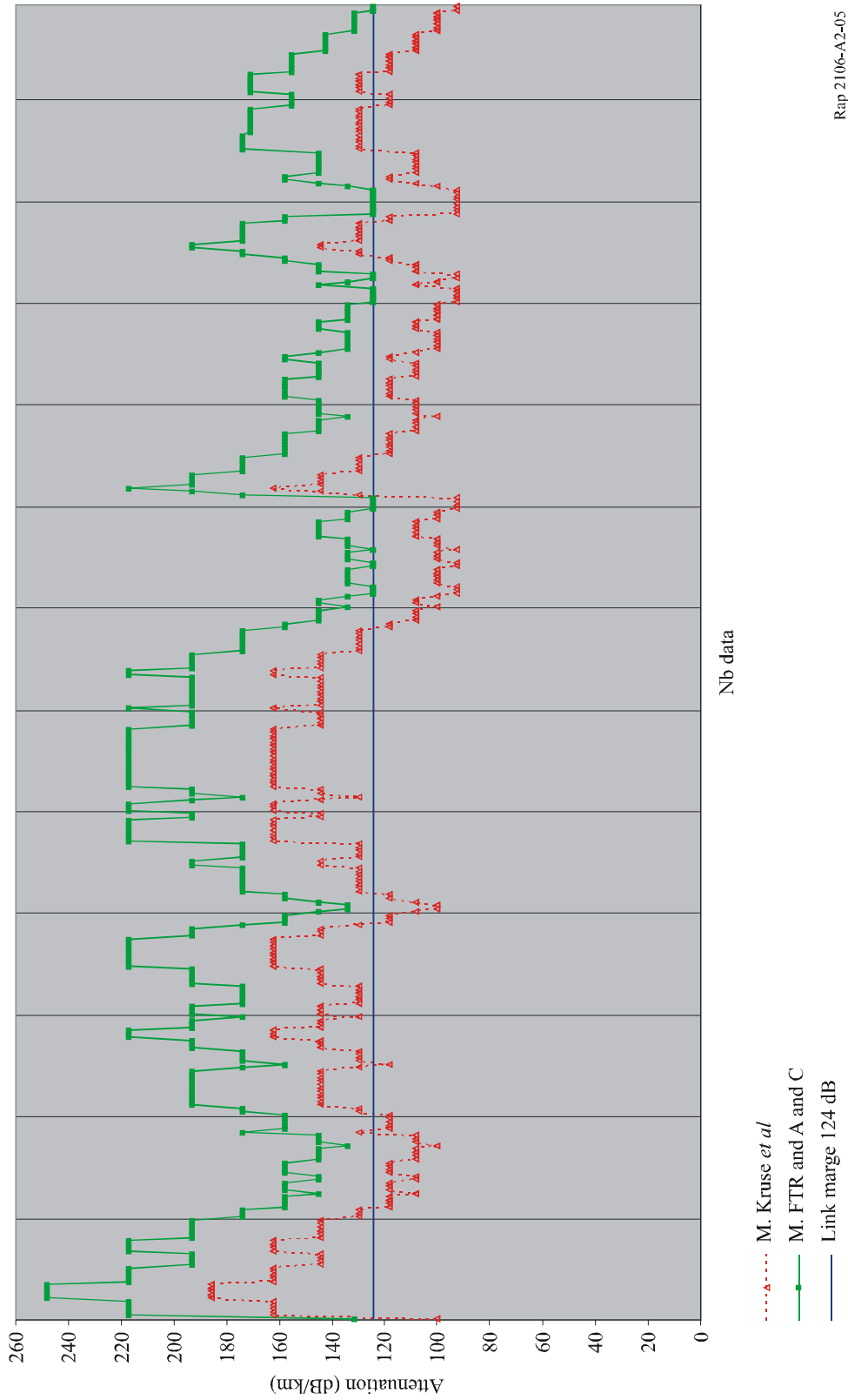

4.1.2 Other attenuation

4.1.2.1 Rain attenuation

Attenuation due to rain is a function of the precipitation intensity R (mm/h) according to the following relation (A-2):

$$Att_{rain}^f = 1.076 * R^{0.67} \quad \text{dB/km} \quad (\text{A-2})$$

where:

R : precipitation intensity (mm/h).

FSO prediction gives us a value of null unavailability for rain attenuation. France weather station indicates that the maximum measurement of rain, during the period considered, was $R = 1.6$ mm of rain over one 6 min period, 13 May 2005; maybe, in pessimistic projection, 16 mm/h.

Rain attenuation: $R = 16$ mm/h, $Att_{rain} = 1.076 \times (16)^{0.67} = 6.89$; $Att_{rain} = 7$ dB/km

Link rain attenuation $Att_{rain-link} = (271 \times 7)/1000 = 1.89$ dB; i.e. $Att_{rain-link} = 2$ dB.

This value is lower than the link margin; therefore the phenomenon does not come to disturb the optical link. The FSO prediction software result is in correspondence with the climatic data of the considered period.

4.1.2.2 Snow attenuation

Attenuation due to the snow is a function of the wavelength (λ_{nm}) and precipitation intensity S (mm/h) according to the following relations (wet snow formula, altitude of the site lower than 500 m) (A-3):

$$Att_{snow} = (0.0000542 * \lambda_{nm} + 5.4958776) * S^{1.38} \quad \text{dB/km} \quad (\text{A-3})$$

FSO prediction gives us a value of null unavailability for snow attenuation. France weather station indicates that snow measurements, at the station, are carried out in two forms:

- snow equivalent water level (corresponds to the quantity of precipitation),
- snow ground level.

During the considered period, the snow level, from Toulouse-Blagnac meteorological station, was not strong enough to have measurable value. We thus have a zero value for the snow climatic phenomenon.

So $Att_{snow} = 0$ dB.

This value is, obviously, lower than the link margin, therefore the phenomenon does not come to disturb the optical link. The FSO prediction software result is in correspondence with the climatic data of the considered period.

4.1.2.3 Ambient light attenuation

Solar conjunction occurs when the sun is in the field of view (FOV) of an optical receiver. FSO prediction calculates, each minute in the year, the probability for which the sun position is parallel to the optical link and the sun power penetrating inside the receiver is greater than the power received from the emitter.

FSO prediction defines the ambient light attenuation calculation by the following formula (Stefan Law-9):

$$F_{emis} = \int_{\lambda=0}^{\lambda=+\infty} \frac{2\pi hc^2}{\lambda^5} \frac{1}{\exp\left(\frac{hc}{k\lambda T}\right) - 1} d\lambda = \sigma T^4 \quad (A-4)$$

where

$$\begin{aligned} \lambda &: \text{wavelength (m)} \\ C &: \text{celerity light (} 3 \times 10^8 \text{ m/s)} \\ T &: \text{Temperature (K)} \\ K &= 1.38 \times 10^{-23} \text{ J/K} \\ \sigma &= 5.67 \times 10^{-8} \text{ Wm}^{-2} \text{ K}^{-4} \\ H &= 6.62 \times 10^{-34} \text{ J/s} \end{aligned}$$

In the spectral window of product FSO (filter in wavelength from 720 to 950 nm), we thus have:

$$F_{emis} = \int_{\lambda=720nm}^{\lambda=950nm} \frac{2\pi hc^2}{\lambda^5} \frac{1}{\exp\left(\frac{hc}{k\lambda T}\right) - 1} d\lambda = 11.5 \text{ MW / m}^2$$

The determination of the level received by the receiver is carried out from the FOV, with 5 mrd value and 100 mm diameter value (A-5).

where:

- Sun diameter: 1.4 million km
- Earth-Sun distance: 150 million km

$$\theta = \arctan g\left(\frac{\text{SunDiameter} / 2}{\text{EarthSunDistance}}\right) \quad (A-5)$$

$$\theta = \arctan g\left(\frac{1.4 / 2}{150}\right) = 0.004333 \text{ rad}$$

$\theta = 4.3$ mrd (lower than 5 mrd), therefore FSO product receives all the light intensity, in certain configuration of position, from the sun.

France weather station indicates that the maximum sun intensity, during the period considered, was $S = 3\,500 \text{ J/cm}^2$, and is approximately equal to $1\,000 \text{ W/m}^2$.

$$C_n^2 = F_1(\text{roughness}) * F_2(\text{solar - radiation}) * F_3(\text{humidity}) * (1 + A)$$

* Solar losses ratio (space + atmosphere)

$$\frac{\text{TotalLightFlux}}{\text{EarthTotalLightFlux}} = \frac{\text{FilteredLightFlux}}{\text{FilteredReceivedFlux}} \quad (A-6)$$

$$\frac{64 \times 10^6 \text{ Wm}^{-2}}{1\,000 \text{ Wm}^{-2}} = \frac{11.5 \times 10^6 \text{ Wm}^{-2}}{\text{FilteredReceivedFlux}}$$

Means: filtered received flux = 180 W/m^2

It is considered that entering flux is completely focused on the receiving diode, that is to say:

$$\text{ReceivedPower} = \text{FilteredReceivedFlux} * \text{ReceptionArea} , \text{ReceivedPower} = 180 * \left(\frac{\pi}{4} * 0.1^2 \right).$$

Therefore, the received power is equal to 1.4 W or 31.5 dBm.

This value has to be compared with the -11 dBm or -16 dBm level received value by the FSO receiver. FSO prediction indicates a 0.000012% unavailability value by the ambient light attenuation. This solar power value is, in some sun position configurations, higher than the received value; therefore the phenomenon influences and disturbs the optical link when the sun is in the direction of the FSO FOV. The result of FSO prediction simulation is in correspondence with the climatic data of the considered period.

4.1.2.4 Scintillation effects

FSO prediction defines the scintillation effect calculation.

France weather station indicates a maxima solar radiation and hydrometry equal to 3 500 J/cm² (either approximately 1 000 W/m²) and 100% respectively.

Scintillation effects: $F1 = 8.99 \times 10^{-14}$; $R=1\ 000\ \text{W/m}^2$; $F2 = 26.6$; $H = 100$; $F3 = 0.19$; so $C_n^2 = 4.5 \times 10^{-13}$

$$L = 270\ \text{m}; \lambda = 850\ \text{nm}; K = 7.4 \times 10^6; \sigma_X^2 = 1.23 \times (7.4 \times 10^6)^{7/6} \times 4.5 \times 10^{-13} \times (270)^{11/6} = 1.65$$

$$A_{ff}^{\text{Scintillation-Link}} = 2.57\ \text{dB}.$$

This value is lower than the link margin; therefore the phenomenon does not come to disturb the optical link. The FSO prediction software result is in correspondence with the climatic data of the considered period.

4.2 QoS comparison and availability FSO versus ITU-R Recommendation

4.2.1 Comparison of QoS FSO versus Recommendation ITU-R F.1668

Recommendation ITU-R F.1668 proposes an error-performance objective for real digital fixed wireless links and it applies to the point-to-point numerical fixed links microwave. In the absence of specific Recommendation related to the FSO, this Recommendation has been used. The objectives of the Recommendation for a 34 Mbit/s access network are given in Table A2-3.

TABLE A2-3
Error performance objective

	Monthly	Annual
Number of ES	< 389	< 4668
Number of SES	< 14 580	< 174 960

The results of the FSOL quality of service, in the two directions and during the considered period, are given in Table A2-4.

From these results and based on the microwave link criteria, the FSOL is not in conformity compared to the quality of service criteria from the Recommendation ITU-R F.1668.

TABLE A2-4

QoS

Month	Direction: From A to B				Direction: From B to A				Results
	Nb ES	Level	Nb SES	Level	Nb ES	Level	Nb SES	Level	
December 04	17	OK	16	OK	120	OK	120	OK	100%
January 05	104	OK	45	OK	619	OK	619	No	75%
February 05	1 048	OK	1 048	No	134	OK	134	OK	75%
March 05	157	OK	154	OK	88	OK	88	OK	100%
April 05	1 688	OK	1 688	No	329	OK	329	OK	75%
May 05	272	OK	264	OK	149	OK	149	OK	100%

4.2.2 Comparison of FSO availability versus Recommendation ITU-R F.1703

Recommendation ITU-R F.1703 proposes an availability objective for any real digital fixed wireless link belonging to the access network and it applies to the point-to-point numerical fixed links microwave. In the absence of specific Recommendation related to the FSO, it is proposed to use this Recommendation. The objectives of the Recommendation for a 34 Mbit/s access network are given in Table A2-5.

TABLE A2-5

Availability objective

	Most unfavourable month	Annual
Availability	> 99.4 ⁽¹⁾ (or 3 154 min or 189 240 s unavailability)	> 99.99 (or 53 min or 3 180 s unavailability)

⁽¹⁾ Based on 100% of availability 11 other months.

The results of the FSOL availability, in the two directions and during the considered period, are given in Table A2-6.

TABLE A2-6

Availability

Month	Direction: From A to B		Direction: From B to A		Results
	Seconds	Level	Seconds	Level	
December 04	0	OK	0	OK	100%
January 05	1 601	OK	38 839	No	50%
February 05	232	OK	0	OK	100%
March 05	13	OK	0	OK	100%
April 05	818	OK	0	OK	100%
May 05	0	OK	0	OK	100%

From these results and based on the microwave link criteria, the FSOL is not in conformity compared to the availability criteria from Recommendation ITU-R F.1703.

4.3 Comparison of FSOL availability versus FSO prediction software

The results of FSO prediction simulation are compared with the FSOL availability recorded during six months. They are presented in Table A2-7.

TABLE A2-7
FSO prediction

	Most unfavourable month	Annual	Results
FSO prediction	96.9849%	99.3037%	Correct
Link FSO	98.5016% ⁽¹⁾	99.8768% ⁽²⁾	Correct

⁽¹⁾ Annual projection

⁽²⁾ Based on the strongest unavailability

The results from FSO prediction software are in correspondence and a little more pessimistic than the FSOL availability, during the considered period; with less than 0.58% over the year and 1.56% in the most unfavourable month.

Remarks and comments

- It should be noted that the margin difference (5 dB) between the two directions of the optical link is perfectly visible in the results of availability.
- A smoke coming from a chimney located on the roof of building A and coming from the kitchens sometimes came to obstruct the optical link, but the caused embarrassment appeared in very precise configurations (temperature, direction of the wind, speed of wind, ...) and was not quantified.
- The sunrise and the sunset also came to obstruct the optical link and software FSO prediction mentions it, but the caused embarrassment could be more frequent.
- The people located around the experimentation site have confirmed the exceptional character visibility values (fog) during the test period (important phenomenon of fog in 2005 not perceived since at least 1995). It is thus advisable to update, at regular intervals, the weather data in FSO prediction software.

5 Conclusion

First, the optical link experimentation made it possible to achieve the two objectives:

- To confront the results with FSO prediction software:
 - The optical link statistical analysis of cut off by the fog highlighted a better precision of the models integrated in the software.
 - The data test synthesis for the other attenuation phenomena are coherent with the results of the software.
 - The software availability results are in correspondence and slightly more pessimistic than the reality of FSOL.

- To confront the FSOL results with the objectives of ITU-R Recommendations, based on the microwave link criteria:
 - The results of optical link are not in conformity with Recommendation ITU-R F.1703, availability objectives for real digital fixed wireless links used in 27 500 km hypothetical reference paths and connections.
 - The results of optical link are not in conformity with Recommendation ITU-R F.1668, error performance objectives for real digital fixed wireless links used in 27 500 km hypothetical reference paths and connections.

References

[BOU 06] Olivier BOUCHET *et al.* [2006] *Free-space Optics: Propagation and Communication*. ISTE Publishing Company. ISBN: 1905209029.

[FSO 04] <http://www.francetelecom.com/en/>.
